

## Wire and Wireless

THE time has long since passed when the title of this journal could have been advanced as an excuse for ignoring or even actively opposing the use of wires for the distribution of broadcast programmes. But in the early days it seemed impossible that there could be people with souls so dead that they would willingly restrict themselves to one programme, however good, when they could experience the thrill of snatching from the ether the sounds and voices of foreign stations by the skilful manipulation of the controls of their receivers. Nowadays the thrill has to a large extent gone, partly because of congestion and a babel of voices on the propagating frequencies, and partly because young people are born into a world in which they find communication without wires accepted as a normal phenomenon of daily life, like motor cars and aeroplanes. The programme's the thing, and both spectators and audience now demand the best possible reproduction and reliability at the lowest cost, irrespective of the technical means of its conveyance.

Before the advent of the B.B.C.'s v.h.f./f.m. service wire distribution was a necessity, notably in some south and east coastal districts, and a convenience in many other districts because of the simplicity of the technical equipment and the reliability of the service. With the spread of television its virtues were again apparent in difficult hilly terrain where if a picture is obtainable at all it is marred by reflected "ghosts." Similarly in fringe areas a wire relay system enables a "clean" signal to be picked up at a point away from roads and buildings and piped back to give a picture free from interference in houses where direct reception would be virtually impossible.

Looking back to the war years and the then mainly hypothetical argument which took place in the pages of this journal on the relative merits of wire and wireless there can be little doubt that the case for wire, then put forward with admirable lucidity by Eckersley, Heightman and others, was founded on sound premises, and that practice has proved its validity. Although proposals to use the electricity supply mains and the public telephone lines have not materialized there has been no lack of variety in the alternative methods which have been adopted by the numerous schemes, large and small, which are now working and which meet the requirements laid down for technical performance in the G.P.O. licencing regulations. These alternatives are discussed in somewhat greater detail elsewhere in this issue.

The political argument against wire, namely that it could be used by unscrupulous authority to restrict the sources of information, has long been discredited. It does not carry any force unless all other media are forbidden. The Dutch have one of the best and certainly the widest-disseminated wire broadcasting networks in Europe, but no one would question their independence as individuals or the democratic character of their government. The history of their wire system is interesting. Before the war there were a number of small privately owned relay companies which were, of course, immediately put under German control during the occupation and further developed by the department of posts and telecommunication. After the liberation the question of whether this system should continue under the control of the Netherlands P.T.T. or be returned to private ownership was freely debated in the Dutch parliament and it was decided that, strong as were the arguments for private ownership, it would be unrealistic to break up an integrated and efficiently run system. Standardization has made it possible to wire new houses and flats with terminal outlets, whether or not the future occupiers elect to make use of the service; but it has also virtually constrained development of television distribution to the so-called low frequencies and the Netherlands P.T.T. is at present concentrating on methods of using effectively the existing network cables.

In this country it will be interesting to observe the development of different, not necessarily rival, technical methods. Even more so to see which, under the influence of commercial competition, provides the best value for money to the viewer (and listener). Whatever the final result, there can be little doubt that the present developmental stage has stimulated receiver manufacturers and retailers to further efforts in providing a service acceptable to potential customers.

Wire distribution will inevitably call for some re-orientation in the receiver manufacturing industry, but in whatever direction change may take place it will not jeopardize the continued production of conventional receivers for replacement or for the needs of those who may have to wait some years before a proven relay system is available as an alternative to direct radio reception in their district. Even then they may well find that their existing receiver fits or can be easily made to fit into the scheme.

"Wire or Wireless" is dead. Long live "Wire and Wireless"!

# Broadcast Entertainment by Wire

## DEVELOPMENT AND PRESENT POSITION OF RELAY SERVICES

**N**EARLY as old as broadcasting itself, the relaying of broadcast programmes by wire to listeners started as a public service in 1927 when the Postmaster General licensed the first operators. Basically, the idea behind relay is so to site receiving aerials and choose equipment that the relayed signals are as good or better than those obtainable by an ordinary domestic receiver at the points served.

At the end of 1927 ten exchanges served, on average, 45 subscribers each. In the early years relay services grew by leaps and bounds until by 1930, 86 exchanges were supplying programmes to 21,677 subscribers. Six years later the total number of subscribers exceeded a quarter of a million. A similar pattern was repeated when, in 1951, television reared—if not its ugly head—its lined face. In each year between 1951 and 1958 the number of viewers “on the wire” has roughly doubled; until at December 1958 there were nearly 200,000 viewers. The number of sound-only subscribers, following the general pattern of broadcasting, reached its maximum in 1954 (1,054,696): since then it has fallen, until at the end of 1958 the number of listeners was about 850,000. Fig. 1 shows the way in which relay services have expanded in the period 1927 to 1958.

**Rules and Regulations.**—The conditions imposed upon the relay operator by the licensing authority—the Postmaster General—are quite severe, both technically and administratively. For instance, quoting from the relay operators’ licences:—

“The Licensee shall not distribute or allow any subscriber to receive by means of any of the stations any programme or message containing political, social or religious propaganda received at the stations in the

English language from any Authorized Broadcasting station outside Great Britain and Northern Ireland, or any programme or message received from any wireless telegraph station announcing the result of any sweepstake in connection with a horse race.

“The apparatus used by the Licensee at the stations, the connecting wires and apparatus used elsewhere shall be of British manufacture.”

“If . . . in the opinion of the Postmaster General an emergency shall have arisen . . . the Postmaster General may . . . require the Licensee to send from the stations messages of any kind or description. . . .”

Other provisions in the licence deal with the satisfactory maintenance of the system, require the operator to inform the P.M.G. of the “state” regarding subscribers and their individual receiving licences (which are still necessary although the operator has to pay an annual fee ranging between £3 and £250, depending on the number of subscribers), keep a “log” and maintain a specified quota of programmes and possibly at two years notice sell his system to the P.M.G. Under this last-mentioned provision he is not entitled to any compensation for the loss of his livelihood or even for the cost of raising the capital to “float” the system in the first place.

The technical requirements of the G.P.O. are divided into two parts—compulsory, and recommended performance standards for the equipment. The mandatory section deals, in the main, with safety and interference standards and the use of G.P.O. lines. Briefly these conditions require proper electrical isolation of the various parts of the system; that, except under special conditions, the voltages applied to the distribution lines must not exceed 65 r.m.s. or 130 direct, and that the field strength of

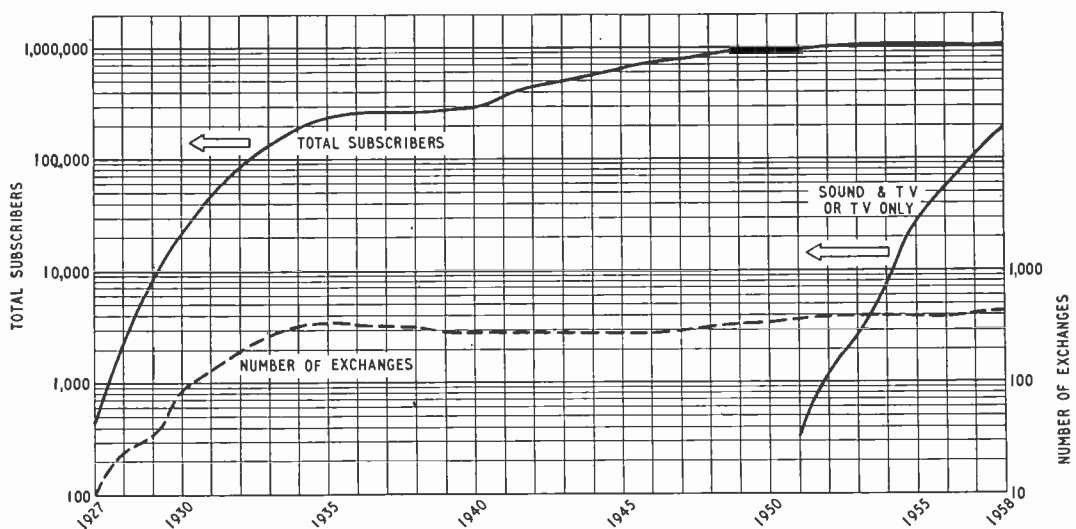

Fig. 1. Expansion of relay services from 1927 to 1958. From 1939 standby and secondary stations are excluded from the total of exchanges. Diagram constructed from figures at 31st December each year (supplied by Relay Services Association).

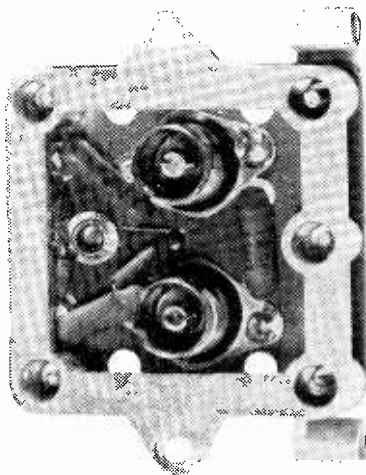

Fig. 2. Interior of Wolsey outlet box for r.f. system. Resistive attenuator isolates sockets from line at r.f., capacitors to B.S.415 provide mains isolation. Two sockets permit use of separate f.m. and TV receivers if desired.

radiation from the system must not exceed  $100\mu\text{V}/\text{metre}$ , ten yards from a line carrying a fully-modulated signal. The recommendations for system performance cover the whole installation from initial reception to the output of the subscribers' equipment. They are both subjective (those dealing with loudspeakers, for instance) and objective; for example, a frequency range of  $50$  to  $7\text{kc/s} \pm 4\text{dB}$  is required for a.f. power amplifiers, with a maximum harmonic content of  $5\%$  up to  $4\text{kc/s}$ . For television pictures the transient response (freedom from overshoot, etc.), definition, contrast range, signal-to-noise ratio and timebase linearity ( $\pm 10\%$ ) are specified.

The relay operator has to obtain permission from the relevant authorities to install his wires. Street crossings are governed by Act of Parliament—the Public Health Act of 1925 and more recently the Highways Act—which invests the local authority with the requisite power to grant permission. No charge can be made for this but generally a local authority is unwilling to allow its town, on the grounds of adversely affecting the amenities, to be covered with the wires of rival concerns. Thus permission is usually given to only one company. In London a special Act—the London Overground Wires Act—applies. On "private" property, whether owned by the local council or an individual, details are settled by negotiation. The usual result is that the relay operator pays the owner of the property a nominal rent—say,  $1\text{s}$  a year—for permission to attach wires to the property.

The relay operator is not allowed to initiate programmes—this authority is vested in the B.B.C. for sound and the B.B.C. and I.T.A. for television. Even simple announcements are precluded, and the only information a relay operator himself can originate are test signals and such transmissions as are covered by the above section of the licence.

## Systems and Equipments

The first type of wired relay to be exploited re-diffused sound programmes at a.f., the subscriber's equipment being a loudspeaker, volume control and, possibly, selector switch. This complies with a good general principle in broadcasting that the listener's (or viewer's) equipment should be the simplest

possible and of the lowest cost; then the complicated and expensive equipment is kept at the central point where it can receive proper maintenance and where its cost will be spread between all the users. The basic system thus consisted in effect of a large radio receiver or receivers feeding extension loudspeakers throughout the town. Initially open-wire lines rather like those used for telephone services were used; but with an increase in the number of programmes provided the necessary multiplicity of lines soon rendered this approach uneconomical (and extremely unsightly), so, generally, a change was made to multi-core cables. One method of obtaining three circuits for a little more than the price of two is phantom operation which uses two pairs of wires as another pair by feeding in the third balanced signal to the electrically neutral points of the two physical pairs. This, though sometimes used, has its disadvantages—mainly that unbalance in any of the circuits can cause crosstalk.

Carrier systems using existing wiring were tried; but it was found that the losses were high at the super-audio frequencies used and, of course, more complicated subscribers' equipment was necessary: also a source of power was required. Carrier systems were thus not popular; although they are used successfully today, for instance in Italy, where the telephone network is employed.\* In passing, a scheme suggested by P. P. Eckersley<sup>1</sup> should be mentioned. The proposition was to use conductors of the existing electricity supply mains as the "inner" of a coaxial cable and the metal sheath as the outer. Single-sideband modulation would be employed to give a six-programme service.

**Television.**—Television of course brought many more problems to relay distribution than did sound radio. Communal-aerial schemes consisting of an aerial sited in a good position and an amplifier which made possible the use of feeder runs to subscribers in blocks of flats, made their appearance in early days. Even in a simple one-programme system receivers have to be isolated from each other so that the chances of mutual interference are reduced and this is usually accomplished by resistive pads (Fig. 2). The gain of the amplifier then compensates for this loss. Feeders have to be installed so that they neither radiate nor pick up signals; but there are few problems that cannot be solved by normal good electrical practice (earthed conduit containing the feeders, for instance) (Fig. 3).

For a whole-town system, however, this did not seem to be an economical method. Distribution at video frequency—the counterpart of a.f. re-diffusion—is not possible because of the band-width involved. Even on a few hundred yards of cable the frequency-dependent phase shift can render the reproduction of good pictures practically impossible.

Several low-carrier-frequency systems were developed, one very elegant method being due to E. J. Gargini of E.M.I.<sup>2</sup> This transmitted the scanning waveforms together with the video and sound information on the same pair of wires and a very simple "receiver" with only three valves was used.

Representative of l.f. carrier operation today is the type of distribution equipment and network used by British Relay Wireless<sup>3</sup> and Central Re-diffusion Services<sup>4</sup>. For a two-programme service

\*As it was in an experiment conducted just before the last war by the G.P.O.

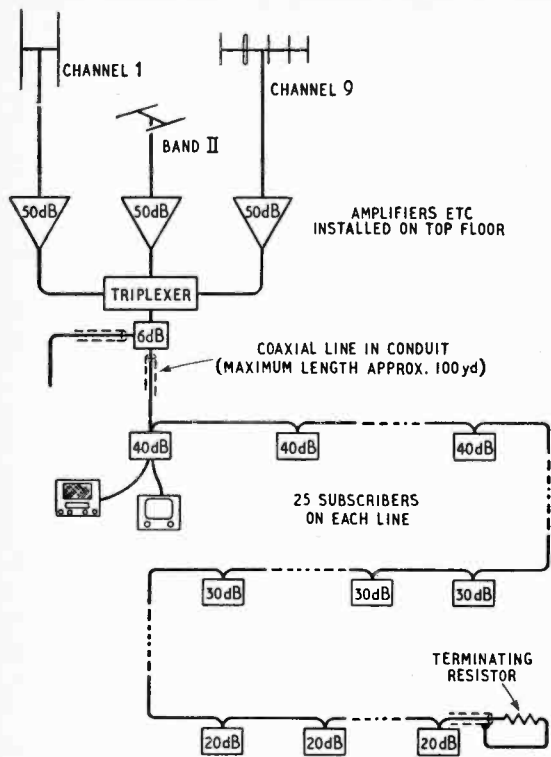

Fig. 3. Typical communal-aerial system for block of 50 flats. Coaxial cable is run in earthed conduit. Note progressive reduction in attenuation of outlet boxes, to compensate for line loss.

a "squad" (screened quadruple) cable was used originally. Crosstalk between the pairs of lines in the cable at 10Mc/s over 250 yd is of the order of 40dB. This is a marginal amount as far as television pictures are concerned; but Kinross<sup>4</sup> has noted that, by adopting a *tête-bêche* system in which one picture is transmitted as the upper sideband of a carrier and the other as the lower sideband of a carrier 3.5Mc/s higher in frequency, a crosstalk of

28dB is tolerable. Thus this system is used with carrier frequencies in the range 3.5 to 10Mc/s. Differential loss in the cable is still a problem, but this is overcome by giving a pre-emphasis to the transmitted signal. Using this type of system line losses are such that cable runs of up to 4,000 yd can be employed without the use of repeater amplifiers. The sound content of the programmes is transmitted at a.f. or at a low carrier frequency on the same cable as the vision signals.

Typical systems using two "squad" cables could provide four television channels and five radio programmes (at a.f.), the fifth a.f. signal being carried on the two cable screens. Also eight-core screened cables are used.

The "viewing unit" is comparatively simple—a selector switch connects the appropriate line to a t.r.f. receiver of about 20mV sensitivity. In all, even when using low-carrier-frequency sound transmission, about nine valves are required.

Naturally, with this type of system an ordinary domestic television receiver cannot be connected directly to the network. However, none of the viewing units available might be aesthetically pleasing to the intending subscriber, or he might own already a television receiver. In this case either a standard receiver can be adapted to accept signals from the line or the relayed signals can be turned back into a form acceptable to an unmodified receiver. Such a facility is provided by B.R.W. in their "Relaydapta"—a simple two-valve converter which translates the line signals into a Band I signal. Rediffusion, Ltd., offer both approaches<sup>5</sup>.

The central-station equipment (Fig. 4) in this type of system can be fairly expensive and complex because of the large coverage achieved without the use of repeaters. For instance, in a bad-signal area the sync. information might be "reconstituted" by fly-wheel circuits. Again, automatic monitoring equipment might be installed to ensure continuity of service by switching in standby equipment should a breakdown occur.

Another type of television and radio distribution system is virtually an extension to the communal-aerial idea: this has become possible due, in the main, to the development of better cables. Aerials are set up at a good receiving point, as they are for

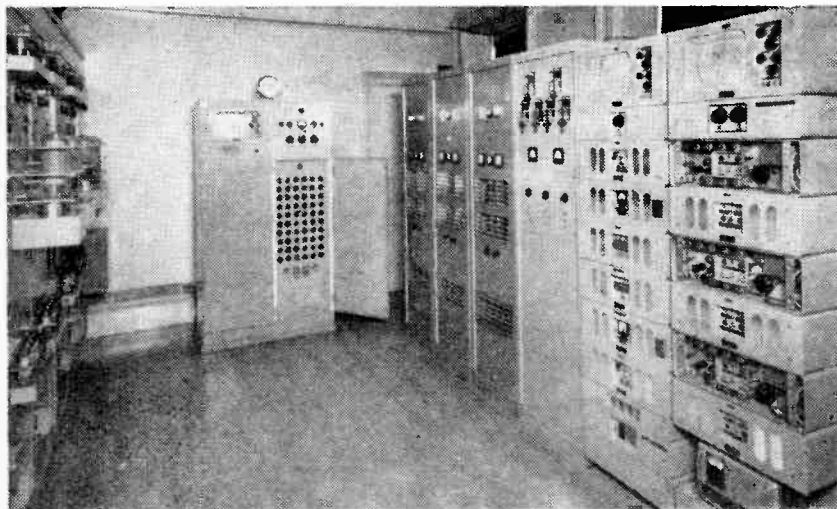
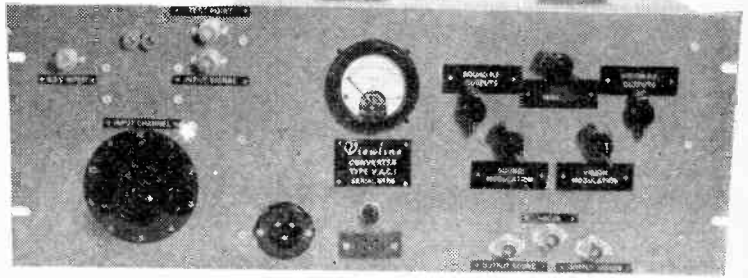

Fig. 4. Low-frequency-system central station at Hawick, Roxburghshire (B.R.W.). Three radio and two television programmes are re-diffused from this centre. Left, a.f. amplifiers; right, TV equipment.

Fig. 5. Viewline Band-III/I converter consists of a receiver, crystal-controlled carrier generators and sound and vision modulators. Pulse generator provides keying pulses for a.g.c. and meter can indicate modulation depth. Line-powering circuits are incorporated to feed mast-head preamplifier.



the l.f. systems, but the signals are fed out after amplification on coaxial cable to subscribers who provide their own receiving apparatus in the form of a standard television or v.h.f./f.m. receiver.

However, Band III still presents some difficulty. The attenuation of a good-quality coaxial cable using expanded polythene dielectric is of the order of 3dB/100ft at 200Mc/s; so it can easily be seen that, assuming a sending level of 100mV, only about 400 yards of cable could be used before the signal became too small to allow a satisfactory signal-to-noise ratio to be preserved at the next repeater (1mV level). Furthermore, subscribers could not be connected to this line as a minimum isolation of 36dB between subscribers (18dB at each tap-off) is necessary to alleviate mutual interference and a minimum signal of 300 to 500 $\mu$ V at the subscribers' outlets is desirable. Also radiation from the cables could lead to interference with direct reception (causing ghosts) and pickup of interference by the cable becomes easier the lower the signal level. For these reasons it is usual to change the frequencies of the received television signals to other channels so enabling higher transmission levels to be used, and convert Band-III signals to Band-I, where cable attenuations are less. Even this brings its own problems, because a simple one-oscillator conversion may produce interfering beat frequencies. Double frequency changing is often employed, or even de-and re-modulation (Viewline, Fig. 5). Cable with either a double layer of copper-braid screening or a lead sheath is used to reduce radiation and pickup.

A typical system would then consist of a central distribution station fed with "clean" signals from the remote receiving site equipment (Fig. 6). From the central point "trunk" feeders radiate to repeater stations 400 to 1,000 yards away. These repeater stations contain amplifiers and would feed the next length of trunk line with an amplified signal and also amplify signals to feed subscribers, who are tapped on to the feed lines through attenuator networks, giving a minimum of 36dB isolation between viewers' outlets (Fig. 7).

This type of system, is, in fringe areas, usually cheaper than an aerial installation which may cost £20 or £30 and is not immune from gale damage. In Boston, Multisignals charge a £5 connection fee, and a weekly rate of 2s 6d.

To avoid the necessity for a mains supply point at every repeater "line powering" is sometimes used. This involves the introduction of low-voltage a.c. (usually 65V) onto the cable. Needless to say, the power that can be supplied is limited by the current-carrying capacity of the cable, so that in a reasonably sized installation several power-injection points are required if many repeater stations (consuming

20 to 50W each) are used. A power saving can be made by using transistors in the repeater amplifiers and this is done by Television Installation Services, who produce a range of transistor equipment in addition to the more usual valve items (Fig. 8).

There is quite a diversity in design arrangements for repeater amplifiers. E.M.I. who supply equipment to Multisignals, G.E.C. (General Piped Television) and Cossor Instruments use distributed-amplifier techniques. Fig. 9 shows part of the circuit of a Cossor amplifier which provides a gain of 20dB from 40 to 220Mc/s. The signal is fed in along a delay line, each stage being tapped down the line. The anodes feed another delay line which "reassembles" the signal by delaying the outputs

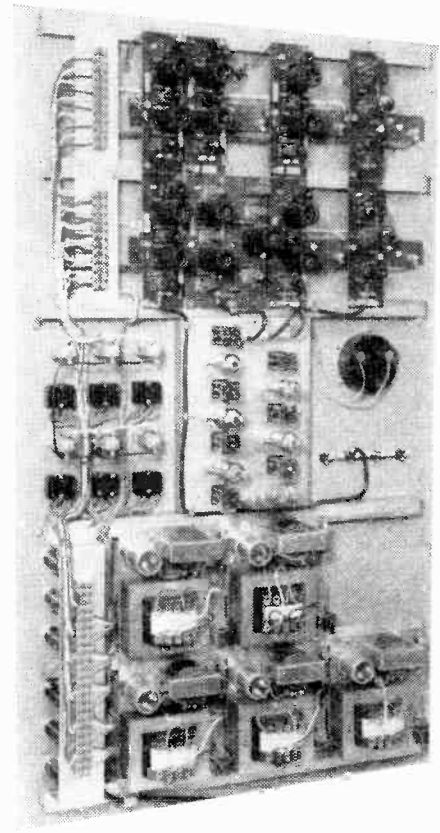

Fig. 6. Belling-Lee main-station equipment. At top are module aerial amplifiers and converter. Band I and f.m. repeater amplifier in centre with space for Band-III wide-band amplifier. Separate power units for each section aid reliability. Equipment is on swing-out door of cabinet.

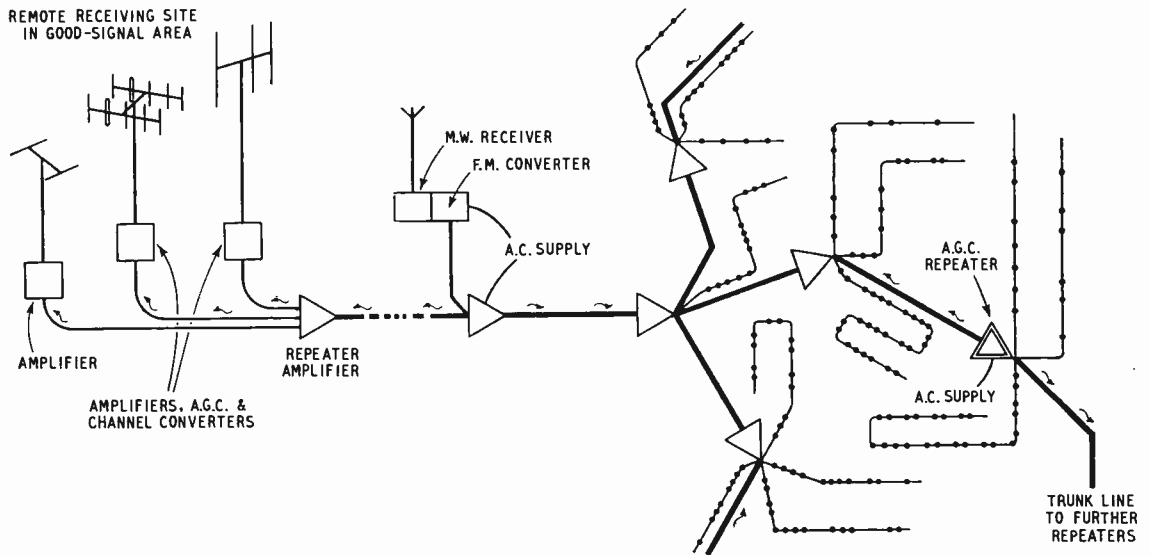

Fig. 7. Layout of hypothetical Band II f.m. distribution system. Heavy lines represent trunk cables feeding further repeaters. Typically 40 to 60 subscribers can be fed from one line.

from the "early" stages so that they coincide with those from the later ones. In this way a valve of high gain-bandwidth product is simulated because the slope is effectively that of the valves in parallel; but their stray capacitances are separated from each other by the delay line. Multisignals have recently opened a Band-I and f.m. system in Boston (Lincs) using distributed amplifiers (Fig. 10). The E.M.I. equipment used there is notable for another feature too—the "Emitap" subscribers' tap off: this is a directional coupler made up from a length of cable. Its feature is that the line-to-subscriber loss is only a few decibels, whilst the loss from subscriber to line can be as high as 40 to 50dB. A major advantage of the distributed amplifier is, of course, that failure of valve results only in a slight loss of gain.

Other repeater amplifiers use a conventional amplifier covering Band I and a separate Band-II amplifier for f.m. (Belling-Lee, Teleng, etc.), or separate amplifiers for each channel (Wolsey).

Two more problems which do not afflict the short-run block-of-flats installation are variation in cable loss (related to temperature) and gain variations in the cascaded amplifiers, due to mains-voltage fluctuations and ageing. These effects are, in the main, additive; so that some form of automatic gain control is usually considered to be necessary after about a mile of cable or four to six repeaters. A.G.C. is achieved in the E.M.I.-Multisignals system by applying an out-of-band pilot signal to the system. This signal is then rectified at the a.g.c.-controlled repeaters. One manufacturer (Fielden; who supply equipment to Viewline), uses repeater-amplifier a.g.c. of the black-level clamping type. The advantages of gated a.g.c. and the pilot-tone system are, of course, that the detail in the dark parts of a bright picture is not lost, rendition of intentionally dark scenes is correct and "clipping" of highlights on a dark picture is avoided.

The majority of manufacturers, however, use a form of mean-level control depending on either sound and vision carriers together or vision only.

Another facility sometimes provided is extra sound programmes on f.m. (for instance, Luxembourg). The m.w. signal is received and demodulated in the normal way and passed to an f.m. modulator (possibly crystal controlled) which provides a signal in Band II for distribution over the network together with the B.B.C. programmes.

Cable-response tilt is overcome either by "tailored" amplifier response or by small frequency-sensitive networks.

**Channel Spacing.**—A Band-I/f.m. service suffers from another disability compared with the I.f. system. As mentioned previously, it is generally desirable not to use the local Band-I channel on the network; although it is often accomplished successfully. This makes difficult the choice of channels because three (B.B.C. and two I.T.A.) television signals are often available at a good-reception site. Channels 1 and 2 are separated by a 3.25-Mc/s gap, so it is reasonable to expect a receiver to be able to separate these. However, the spacing between the remaining four channels is only 1.5Mc/s and some receivers may suffer from adjacent-channel interference if these channels are used simultaneously. Teleng adopt the combination 1, 2, "3½," 5 (using to date a maximum of three) whereas General Piped Television plan to accommodate six channels by reducing the spacing between 1, 3 and 5 and providing three artificial channels between 66Mc/s and 85Mc/s. This would require non-standard coil "biscuits" in the set tuner for the extra channels and might well prove difficult where incremental or other "pre-engineered" tuning arrangements are used, but should not prove an insurmountable problem. Viewline employ channels 1, 2, 4 (minus 1Mc/s) and 5 (plus 1Mc/s). The alternative is to utilise Band III as well; but unless better cable is used closer repeater spacing will be necessary. E.M.I. and Cossor provide suitable distributed amplifiers.

Another solution to the problem is put forward by General Piped Television. This is to convert all

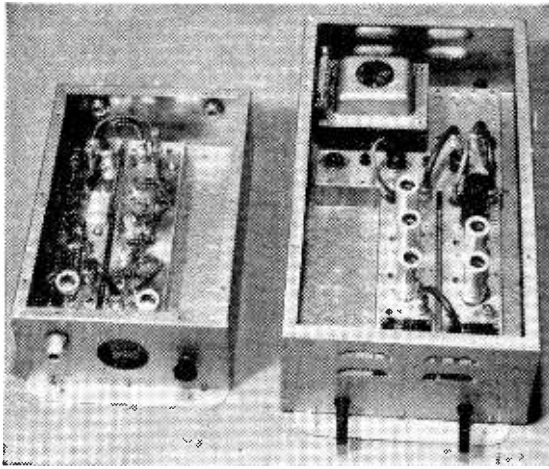

Fig. 8. D.C. line-powered Band-I transistor repeater (left) compared with its 65-V a.c. valve equivalent (right). Note absence of power pack in transistor equipment. Power requirement is only 15V, 20mA and 25V, 600mA is fed onto line. (Television Installation Services.)

signals to low-frequency carriers at the aerial equipment, and then convert back to Band I and III at each subscriber-feeding repeater. In this way very-long trunk-cable runs (on a par with those used by B.R.W. and Rediffusion) could be employed without repeaters, so compensating for the extra cost of a greater number of channel converters.

### The Future

Relay, both sound and vision, has always had a chequered career. It has been under fire from the radio retailer because, in the past, it has resulted in a loss of his trade. It has been threatened with nationalization<sup>6</sup> and condemned as politically totalitarian.<sup>7</sup>

First, then, the retailer; the Radio and Television Retailers' Association say:

"Experience has taught us that the expansion of low-frequency systems using specially manufactured terminal equipment which is distributed through the

company's own outlets, is completely incompatible with the interests of the retail section of the industry. We, therefore, as a matter of trade policy, clearly favour the development of systems using domestic receivers, and we are also advised that technically there are many advantages to the latter.

"Should further expansion of television broadcasting take place, it would be necessary for most low-frequency systems to rewire, if they wish to bring extra vision channels into operation. This, we feel, is an unnecessary expense and one which can be avoided by using the type of system which is advocated by, say, Multisignals, Ltd., where high-quality coaxial cable is used and wide-band distributed amplifiers capable in their most advanced form of distributing 30 signals, including at least seven television channels. Thus, when this type of system is initially installed it can confidently be stated that it is quite capable of taking care of future expansion (e.g., receiving higher definition and colour signals without modification). Multisignals, which is now backed by leading manufacturers, was promoted very largely by this Association and the Council has given formal approval to the policy of this company as being not only the fairest as far as dealers are concerned, but technically the most advantageous."

Another organization—Telesurance Ltd.—provide, for groups of retailers, advice and consultative services from company formation to technical planning and supervision of installation. In the last two years twenty-five companies—Trader Television Relay, as they are called—have been formed and are operating relay systems, one of the most recent of which is now being installed in Cheltenham.

R.F. systems will have to compete with the established low-frequency distribution systems in which the essential difference is that the viewer is provided with a guaranteed picture rather than a good signal service at an aerial socket. Rental terms for the low-frequency system (typically 12s 9d reducing to 8s 9d for a combined sound broadcast reproducer and 17in television display unit) include quick service (i.e., within 12 hours) at no extra charge.

Both systems have the advantage of giving viewers in poor-signal areas better pictures at lower cost than would be possible with independent receivers and aerial systems.

The threat of nationalization has been with relay for a long time—the Ullswater report appeared in 1935, recommending that relay services should be

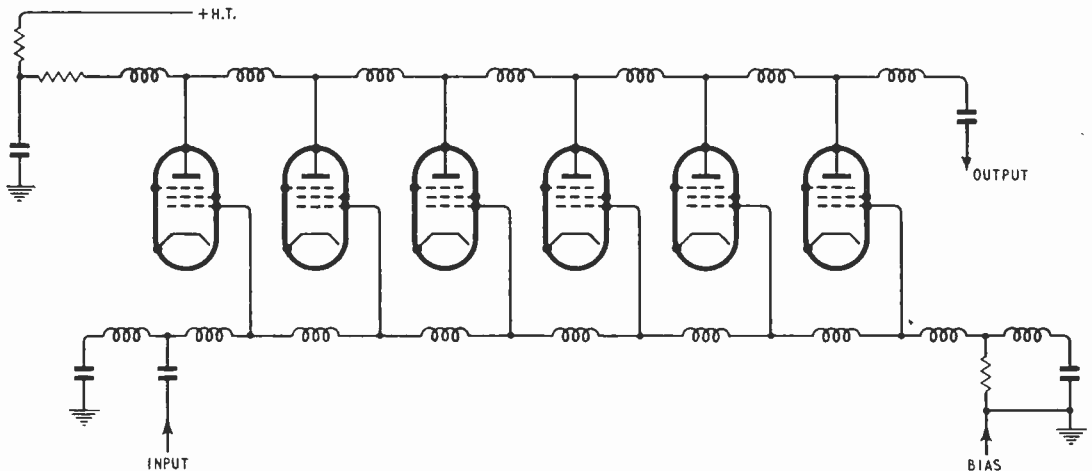

Fig. 9. Part of circuit of Cossor distributed amplifier. Output feeds similar circuit to give gain of 20dB from 40 to 220Mc s.

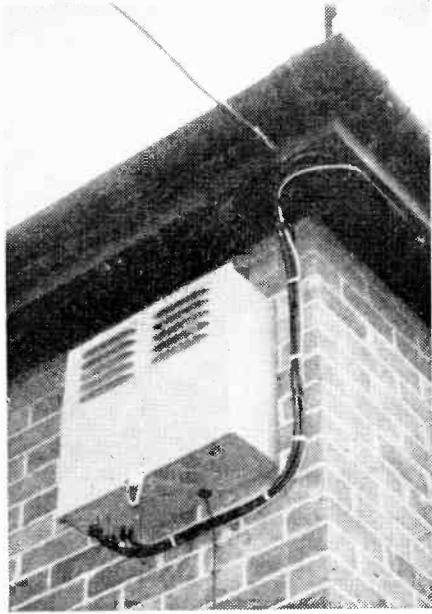

Fig. 10. E.M.I. repeater for 40 to 110Mc/s system mounted under eaves of house (Multisignals installation at Boston). L.F. systems transmit at high levels: repeaters resemble main-station television power amplifiers.

state-run. It is this, presumably, that is perpetuated in the "two-years notice" clause of the relay operators' licences.

If a relay system were to replace over-the-air broadcasting on medium waves (which was the idea attacked in ref. 7), then the situation would not be unlike that pertaining in Germany before and during the last war, when the "Volksempfänger"—a receiver of strictly limited range and selectivity—was one of the bolsters of Hitler's power. However, present-day primary-service broadcasting is tending to take place on v.h.f./f.m. and television, both of which are limited in range to about 80 miles except under unusual conditions. Thus it might be argued that the only effect of the total replacement of the f.m. and television services by wired relay would be to clear urgently-needed and valuable frequency bands for other users.

We may guess safely that whatever new (or old) standards the Television Advisory Committee recommend for future expansion of television in the United Kingdom the transmissions will have to take place at frequencies higher than Band III. Reception problems will thus be greater. In view of this, the prospect of getting one's programmes by wire becomes even more attractive.

It is, perhaps, wrong to speculate further on the future of television relay whilst still awaiting the T.A.C. report; but system potentialities are an important part of the planning of a service as the economic life of a relay scheme may have to be set at anything over ten years. If a change to a high-definition standard, even as high as the French 819 lines with its 10-Mc/s bandwidth, were to be made, then the low-frequency systems could probably accommodate it, as the cables in use have been shown to be capable of accommodating a 10-Mc/s bandwidth (2 to 12Mc/s).<sup>3</sup> This type of system,

too, is rather more suitable for the installation of a standards converter so that a high-definition programme, if of different content, could be relayed to subscribers on 405 lines, as an interim measure. Additional cable pairs would be necessary for more than four programmes unless techniques were modified drastically. On the other hand, a Band-I-only wired-aerial scheme is probably running now at its full potential with three programmes. Band-I and f.m. systems, using repeaters covering 40 to 110Mc/s or so, are a little better off as there is room for one, or maybe two, transmissions of bandwidth wider than 3.5Mc/s; but it is, of course, the Band I/III systems which show the greatest potentiality as the whole of Band III, with the additional few megacycles between Bands II and III, could be used. However, any arrangement using frequencies other than those in Channels 1 to 13 and standards other than 405 lines negate entirely the advantages of Band I/III wire-aerial systems, because receiver modification or non-standard receivers would be necessary.

Is it too much to ask, though, that some responsible authority, as soon as the T.A.C. report is published, should make a careful study of the relay field with a view to recommending a "standard" transmission system? Viewing and sound reproduction units could then be put on sale to the general public. The ordinary domestic television receiver, with its flywheel sync., interference limiters, turret tuner, a.g.c. and high sensitivity, is unnecessarily complicated and expensive for use with "wired" signal.

### Acknowledgments

We would like to acknowledge the co-operation of the following organizations who supplied information and illustrations:—

Belling & Lee Ltd., British Insulated Callenders Cables Ltd., British Relay Wireless Ltd., Cossor Instruments Ltd., Faraday Electronics Ltd., Gate Electronics Ltd., General Post Office, General Piped Television Ltd. (and G.E.C. Ltd.), Multisignals Ltd. (and E.M.I. Electronics Ltd.), Rainbow Radio Ltd., Radio Retailers' Association, Rediffusion Research Ltd., Relay Services Association of Great Britain, Telling Ltd., Telesurance Ltd., Television Installation Services Ltd., Viewline (Planning) Ltd., Whiteley Electrical Radio Ltd., Wolsey Electronics Ltd.

### REFERENCES

- 1 Broadcasting over the Mains, by P. P. Eckersley, *Wireless World*, Vol. 47, p. 298 (December 1941).
- 2 "Piped" Scanning Waveforms, by E. J. Gargini, *Wireless World*, Vol. 61, p. 83 (February 1955). (See also *Journal of Television Society* and *Proceedings of Society of Relay Engineers*.)
- 3 A Common Carrier Multi-channel Television Wire Broadcasting System, by K. A. Russell and F. Sanchez. Paper delivered at the Brit.I.R.E. Television Convention, 1959. To be published in the *Journal of the Brit.I.R.E.*
- 4 Distribution of Television by Wire, by R. I. Kinross. *Proceedings of Society of Relay Engineers*, Vol. 4, No. 2 (May 1957).
- 5 Piped TV (Letter to the Editor), by R. P. Gabriel, *Wireless World*, p. 183, April 1960.
- 6 Report of the Broadcasting Committee ("Ullswater" Report), presented Dec. 31st 1935 (C.M.D. paper 5091).
- 7 See, for instance:—Isolationist Broadcasting, Broadcast Distribution: The Case for Wireless, Against Wired Broadcasting. *Wireless World*, pp. 223, 227, 255, Vol. 49 (August and September 1943).



# Dynamic Side Thrust in Pickups

CAUSES AND CURES

By H. J. F. CRABBE

**D**URING the past two years a great deal of well-deserved attention has been paid to pickup arm design, and the recent production of cartridges to track at very low pressures has provoked a heightened interest in the subject. Many older arms introduce extraneous forces of some magnitude, which have nevertheless remained undetected because they do not upset pickups tracking mono discs at 8 or 10 gm. With stereophonic records, however, a drastic reduction of unwanted stresses at the stylus is required if a pickup is to give of its best.

Recent work\* has shown that by the careful distribution of mass and the reduction of pivot friction, static forces at the stylus due to these causes can be virtually eliminated. But, despite all improvements on these lines, there remains the much larger dynamic side thrust caused by stylus/record friction. There is still a large amount of confused thinking on this problem, and this article attempts to explain and clarify the causes of the trouble and outlines some possible cures.

**Causes.**—When a record is made the cutting stylus moves along a true radius, but when it is reproduced the pickup stylus cannot do this, since the arm is pivoted at a finite distance from the record. Hence the expediency of an offset head to minimize tracking error. This is illustrated in Fig. 1, which shows the geometry of a typical 8-in arm with an offset angle ( $\theta$ ) of  $24^\circ$ . As the groove passes the stylus it provides a forward drag which is tangential to

the record groove at the point of contact. This is in the direction D on the diagram, and its line of action is displaced from the pivot (P) to the extent of the linear offset (O). Thus this forward force produces a clockwise moment about the pivot which tends to press the stylus against the inner groove wall in the direction F.

The geometry of the situation is such that the inward thrust is equal to the forward drag multiplied by  $\tan \theta$ . (This is an approximation which assumes that the centre line of the head and stylus system is always tangential to the record groove; it should be within  $2^\circ$  on a well-arranged 8-in arm.) The forward pull itself is equal to the downward force at the head multiplied by the coefficient of sliding friction between stylus and record. Thus the theoretical expression for side thrust is  $S = \mu W \tan \theta$ , where  $\mu$  is the coefficient of friction and W the downward force. With an 8-in arm  $\theta$  is  $24^\circ$ , and  $\mu$  for a smooth hard stylus and unfilled vinylite is about 0.3; this gives  $S = 0.135W$ . Practical measurements show a side thrust that is between 10% and 12% of the downward force, which can be considered reasonable confirmation of the theory.

A typical high-quality pickup working at a downward force of 4gm might have a lateral stylus compliance of  $5 \times 10^{-6}$  cm per dyne. The associated side thrust, on the above reckoning, would be 0.5 gm—producing a steady stylus displacement of  $25 \times 10^{-3}$  cm. Such a deviation is comparable with the maximum recorded modulation, and could easily lead to trouble on stereophonic pickups through magnetic unbalance of the generator and/or mechanical unbalance of the stylus dynamics.

**Some Variables.**—The above considerations assume that the coefficient of friction is a constant factor, but in practice there are some variations which call for comment. In theory the frictional restraint between moving surfaces is independent of their relative velocity; though this does not seem to apply to vinylite records, as there is slightly less stylus drag at smaller radii than larger, and more at 45 r.p.m. than 33 1/3 r.p.m. at a given radius. The resulting change in side thrust between the outer and inner grooves of a 12-in disc is approximately in the ratio 1.2 to 1.0, and any attempt at compensation should take account of this.

Theory also predicts that the coefficient of friction should remain unaffected by the pressure between the surfaces. This means that the horizontal force required to move the record past the stylus at constant velocity should always be the same fraction of the downward force (i.e. 0.3). This has been challenged by at least one investigator\* on the ground that plastic deformation is a special case where friction is not linearly related to pressure. It is argued that a stylus working within the elastic

Fig. 1. Arrangement of a typical 8-in arm, where the offset angle ( $\theta$ ) is  $24^\circ$ .

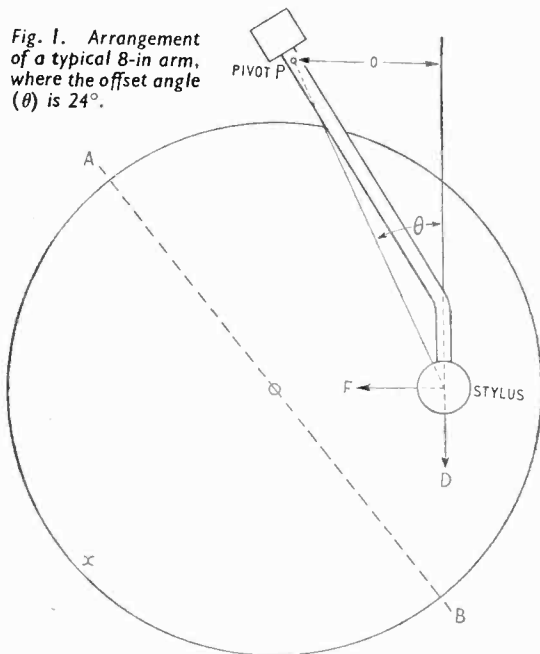

\* J. Walton, "Pickup Arm Design", *Wireless World*, June 1959, pp. 269-272.

region of the record material at very low pressures will experience much less frictional drag and consequently produce negligible side thrust.

However, this author's rather clumsy experiments with a particular pickup do not support this view. Measurements at pressures producing visible and invisible markings respectively (a rough indication of deformation) show only a very small reduction of friction for the latter. Therefore, pending further evidence, we must assume that any pickup with an offset angle of  $24^\circ$  will inevitably produce a side thrust that is at least 10% of the downward force, no matter how small the latter may be.

The discussion so far has been based on pickup behaviour on blank vinylite discs; but it is reasonable to suppose that the situation in an unmodulated groove will be similar, as this is equivalent to a slight increase in contact area, which should not affect frictional drag. Modulation, however, is like roughening the record surface, and it will probably increase both friction and side thrust—possibly by a very large factor. One cannot be certain of this, however, as at high modulation velocities the stylus tends to leave the groove surface, and at such times the frictional drag will momentarily fall to zero.

It would be useful to measure the actual "d.c." deflection of a pickup stylus in both modulated and unmodulated grooves; but this is difficult in practice, as the attachment of strain gauges or other devices would raise the stylus impedance, thus increasing friction and altering the side thrust being measured. A possible approach is to use a crystal pickup, which is, strictly speaking, an "a.c./d.c." device. This necessitates feeding into a very large resistance so that the time constant formed by the crystal capacity and the load is long enough for a useful measurement to be made when the stylus is deflected. Unfortunately, in practice, crystals have an internal shunt resistance of the order of ten megohms unless very special precautions are taken in manufacture.

An indirect method of measurement, which assumes that the side force is always equal to the forward drag multiplied by  $\tan \theta$ , is to ascertain the forward drag directly by means of a straight arm pulling a calibrated spring. Such a device could perhaps measure the frictional drag on a blank disc or in grooves both modulated and unmodulated, and at any radius or downward pressure with any size of stylus. The author hopes to conduct such a series of experiments in the near future.

Whatever the outcome of such investigations, it is probably a safe assumption that side thrust will

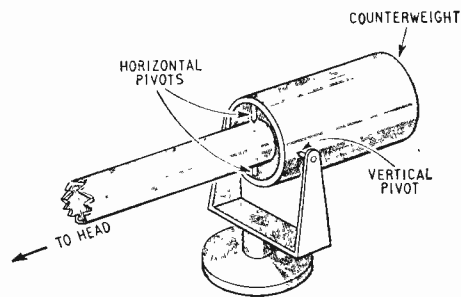

Fig. 2. Pivot system which decouples the counterweight from lateral movements of the arm.

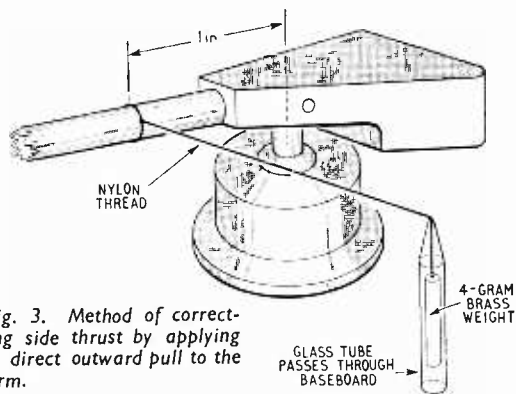

Fig. 3. Method of correcting side thrust by applying a direct outward pull to the arm.

always be at least that which arises on a blank disc; if it falls to zero due to the stylus leaving the groove, then the effect of any compensatory force will likewise be removed.

**Some Cures.**—When lowered on to a level rotating blank disc, a normal pickup will move rapidly towards the centre under the action of side thrust. Any unit failing to do this is probably suffering from excessive bearing stiffness, though the deliberate use of pivot friction to counteract side thrust is inadmissible; not only would it be an unpredictable quantity, but whenever the arm was momentarily stationary it would be inoperative. On an eccentric record the pickup may actually move outwards, in which case pivot friction would add to the dynamic side thrust.

A more sensible approach is to fit a spiral spring to the horizontal pivot, arranged to produce an anti-clockwise force. Two such springs working in opposition can be made to produce an outward thrust which diminishes towards the inner grooves, thus allowing for reduced stylus drag at smaller record radii.

Not all of us are watchmakers, however, which may account for the popularity of "dynamic leveling", a method of compensation ably advocated for some years by Mr. Wilson of *The Gramophone*. It consists of tilting the whole turntable and pickup assembly in such a manner that some of the downward pressure is converted into an outward-acting side pressure. In Fig. 1 the tilt should be along a line such as AB and with x as the highest point, so that the angle of climb falls with decreasing record radius. In accordance with the requirement for decreasing compensating side thrust with decreasing record radius already mentioned, in our typical case the optimum direction for the tilt axis AB will be roughly parallel with the line joining the pivot and stylus when the pickup is at the other grooves.

With most arms where the effective head mass is the same vertically and horizontally, the required angle of tilt ( $\alpha$ ) is given by side thrust ÷ downward force =  $\sin \alpha$ . For a side thrust that is 12% of the downward force this gives an angle of  $7^\circ$ . Problems of cabinet construction and the use of turntables designed to work horizontally make this method of compensation rather awkward in practice, but fortunately there is a variation of the same principle requiring much less tilt.

The actual mass of material in front of the main pivot on most pickups is very much greater than the

downward weight at the head, the difference being cancelled out by counterweights or springs. In the latter case, the full weight of the arm and head is brought into play when the system is tilted, and if this weight is, say, thirty times the downward weight, then a tilt of only  $0.25^\circ$  will be required to produce a side thrust equal to 12% of the downward weight. (For this reason accurate levelling is absolutely vital with countersprung pickups!)

However, springing is generally a rather indefinite and unsatisfactory method of force adjustment, so what is needed is a counterweight which acts in the normal manner vertically but is immobile laterally. Fortunately this is fairly easy to arrange and Fig. 2 shows a possible design. Using such a system it is unlikely that a tilt of more than  $1^\circ$  would ever be required for full compensation, and no special fixing of the turntable baseboard is necessary. Owing to the small tilt it is essential to make adjustments by the practical method of ensuring that the pickup remains stationary on a rotating blank disc at all radii used in practice.

For those not wishing to purchase or build new arms for otherwise perfectly good pickups, there is a further method of compensation, adopted with complete success by the author. It uses a direct outward pull on the pickup arm by means of a brass weight suspended on a thread passing over a pulley. This is illustrated in Fig. 3, where the "pulley" is a glass tube drawn to a fine nozzle and rounded in a flame for a smooth surface. The thread is a single strand of 0.005-in diameter nylon (Luron fishing line No. 2) which runs with negligible friction into the glass tube when smeared with a light oil.

It is worth noting that if the brass weight is made equal to the downward force and the nylon thread is parallel to the side thrust, the ratio of the distances from pivot to stylus and pivot to nylon thread will equal the ratio of downward force to side thrust. In the case of our typical 8-in pickup working at 4 gm with a side thrust of 0.5 gm, the counter force will be applied 1 in from the pivot as in Fig. 3.

Fig. 4. As the pickup crosses the record the angle  $\beta$  decreases, thus providing less outward pull at the inner grooves.

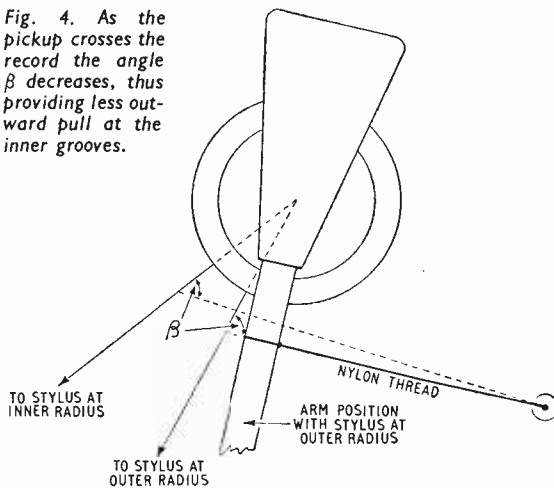

This is useful as a rough guide to the weight needed at a given distance from the pivot or to the distance from the pivot needed for a given weight.

As with correctly-arranged "dynamic balancing", this system can also compensate for the change of side thrust across the record, as shown in Fig. 4. The angle ( $\beta$ ) between the thread and a line joining the pivot and stylus diminishes as the pickup crosses the record, and if in our typical case the initial angle at the outer grooves is set to about  $75^\circ$  and the horizontal portion of the nylon thread is about 2 in long, the resulting reduction of torque during traverse corresponds roughly to the fall in side thrust.

Finally, it is well to remember that the use of pivoted arms with all their accompanying difficulties is little more than an interim compromise. Sky-hooks may not yet be in the shops, but a true friction-free radial-tracking device is likely to be the eventual solution to the side pressure problem.

## SHORT-WAVE CONDITIONS

Prediction for May

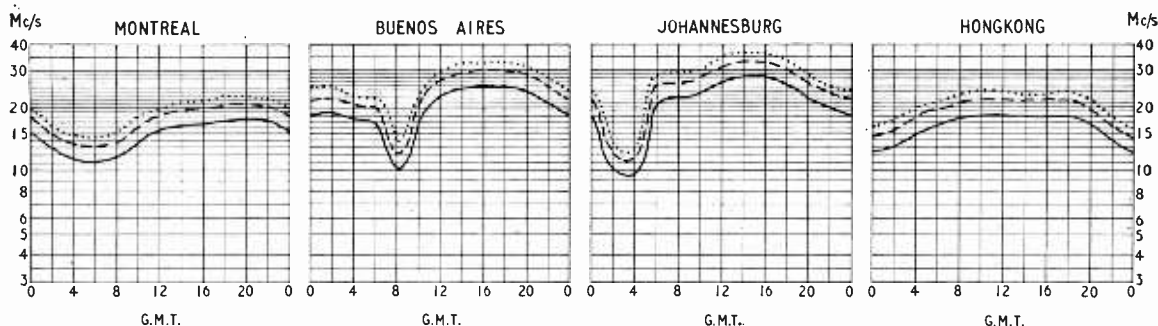

THE full-line curves indicate the highest frequencies likely to be usable at any time of the day or night for reliable communications over four long-distance paths from this country during May.

Broken-line curves give the highest frequencies that will sustain a partial service throughout the same period.

- ..... FREQUENCY BELOW WHICH COMMUNICATION SHOULD BE POSSIBLE FOR 25% OF THE TOTAL TIME
- PREDICTED MEDIAN STANDARD MAXIMUM USABLE FREQUENCY
- FREQUENCY BELOW WHICH COMMUNICATION SHOULD BE POSSIBLE ON ALL UNDISTURBED DAYS

# WORLD OF WIRELESS

## **U.H.F. Television Problems**

ALMOST half the permits issued since 1952 for building u.h.f. television stations in the U.S.A. have been surrendered and more than half of the u.h.f. stations which were in operation have closed down. This is announced by the chairman of the Federal Communications Commission in his year-end statement covering the 25th year of the Commission, which is charged with "regulating inter-state and foreign communications by means of radio, wire and cable." How to resolve the u.h.f. problem is said to be one of the Commission's greatest perplexities. Experience with an "inter-mixture of v.h.f. and u.h.f. operation has been disappointing" and the possibility of reducing the present geographical separation between v.h.f. stations is therefore being considered.

Out of a total of some 500 commercial television stations in operation only 76 are now in the u.h.f. band. There has, however, been a slight increase in the number of permits granted for the operation of u.h.f. television translators to serve remote localities.

Other points of interest from the chairman's report include:—

The F.C.C. licensed 570,000 radio stations operating well over 1,700,000 transmitters.

Amateur radio stations increased from 188,600 to nearly 203,000.

Transmitters providing communication on land, water and in the air "in the interest of safety of life and property and to serve commercial and individual needs," totalled about 1,700,000, an increase of 300,000 during the year. The total number of transmitters in round figures in the main groups, with the 1958 figure in brackets, was:—Marine 95,000 (80,000), aviation 125,000 (85,000), land transportation 445,000 (345,000), industrial 538,000 (420,000) and public safety 332,000 (307,000).

## **New Zealand Television**

EARLY last year the New Zealand government decided on the standards\* to be employed when its television service is introduced. Now the government has made a statement on its policy in general. From this it is learned that the service will be "state owned and operated" on both "non-commercial and commercial lines" as is the country's sound broadcasting service. During this year experimental low-power stations will be opened in Wellington, Christchurch and Dunedin (Auckland already has an experimental station).

It is also stated that the government will control the manufacture of television receivers by means of import licences and will decide how many sets the industry will be permitted to make. Commenting on this point our New Zealand contemporary, *Radio and Electrical Review*, states, "It will certainly look slightly odd, to say the least, to the student of New Zealand affairs, that the same government which has introduced legislation on trade practices, and which, through its Commission has

evidenced such concern for the public purse as to prevent the price-fixing of hair-cuts, has in almost its next breath indicated that it will artificially keep up the prices of television receivers! . . . If it is in the public interest to have television at all, then surely it is in that same interest to have it as economically as possible."

## **Amateur Convention**

AFTER a lapse of six years the Radio Society of Great Britain is organizing another National Convention. It will be held in Cambridge from September 15th to 17th. Although final details are not yet available it is known that among the speakers will be J. A. Ratcliffe, of the Cavendish Laboratory (who succeeds Dr. R. L. Smith-Rose as director of the D.S.I.R. Radio Research Station in September), and Martin Ryle, professor of radio astronomy in Cambridge University.

Attendance will not be restricted to members of the Society. Further details are obtainable from the convention secretary, Howard Waton (G3GGJ), "Arkengarthdale," New Road, Barton, Cambridge.

## **West German Industry**

PRODUCTION of sound and television receivers in West Germany rose from 5,345,000 in 1958 to 6,133,000 last year—an increase of 14.7%. Of the 2M television sets produced last year 82% had 21-in tubes. Although the number of sound radio receivers produced rose by 11.5% to over 4M, the overall value increased by only 4% to DM720M. This is accounted for by the fact that there has been a considerable increase in the production of small portables. There was a slight decrease in the number of radio-gramophones produced—487,000 compared with 490,000.

Television receivers must now comply with a recently introduced government regulation limiting spurious radiation. Specimen receivers are tested by the Fernmeldetechnisches Zentralamt (FTZ) and if approved, are assigned a test number which is published in the official publication of the Federal Ministry of Posts and Telecommunications.

West German sound radio and television exports increased from 1,950,000 receivers in 1958 to 2,180,000 last year.

## **European Broadcasting**

THE European Broadcasting Union reports that as a result of a meeting of delegates from European broadcasting organizations held in Geneva during the recent Administrative Radio Conference, the Copenhagen Plan for long- and medium-wave broadcasting stations in Europe will remain in force for at least another five years.

Also at Geneva the limits of the European Broadcasting Area were modified so that it now includes Iraq. The following stations should therefore be added to the medium-wave list in "Guide to Broadcasting Stations":—Salman Pack 566, 650 and 970kc/s; Kirkup 605, 738, 764kc/s; Abu Ghuraib

\* 625 lines, 7-Mc/s channels, f.m. sound, using three channels in Band I and six in Band III.

850, 908, 1295kc/s; Mosul 870, 1420, 1500kc/s; and Basrah, 1187, 1277, 1376kc/s.

Another change in the stations operating on the periphery of the area is brought about by the closing of six privately operated transmitters in Tangier. They are:—Radio Africa, 593 and 935kc/s; Radio International, 1079 and 1232kc/s; Pan American Radio, 1128kc/s and Radio Intercontinental, 1594kc/s. It is reported in the *E.B.U. Review* that under an agreement between the Moroccan and U.S. governments the Voice of America transmissions from the present Tangier short-wave station may continue until 1963. The agreement includes the provisions that a 100-kW and a 50-kW transmitter must be put at the disposal of Radiodiffusion Marocaine for 80 hours a week and at the end of the period of the agreement the majority of the equipment will become the property of the Moroccan State.

**Royal Society Tercentenary.**—Her Majesty the Queen, who is Patron of the Royal Society, will open the society's tercentenary celebrations in the Royal Albert Hall, London, on July 19th. She will be accompanied by His Royal Highness, the Duke of Edinburgh. The celebrations will continue until July 26th.

**Intervision** is the name given to the international television network being set up by Eastern European broadcasting authorities under the aegis of the International Radio and Television Organization (O.I.R.T.). The network at present links Hungary, East Germany, Poland and Czechoslovakia and in the near future television transmitters in the Soviet Union, Bulgaria and Rumania will be added. Representatives of the O.I.R.T. and the European Broadcasting Union (U.E.R.) recently met in Geneva to discuss the linking of the Intervision and Eurovision networks.

**Data Transmission.**—An international symposium on the problems of transmitting and receiving information in digital form is being organized by the Benelux section of the American I.R.E. for September 19th and 20th. It will be held in Delft, Netherlands, but will be conducted in English. Details are obtainable from B. B. Barrow, secretary, The Benelux Section, I.R.E., Postbus 174, Den Haag, Netherlands.

**Autonomics Division** is the new name adopted by the National Physical Laboratory for its Control Mechanisms and Electronics Division. By working closely with biologists in studying the methods which living physical systems use to achieve control, the newly named Autonomics Division (meaning "self-governing") hopes to discover underlying principles on which machines capable of improving their own performance can be built.

**Receiving Licences.**—The February increase in the number of combined TV/sound licences in force in the U.K. was 148,456, bringing the total to 10,368,323. Sound-only licences, including 422,780 for car radio, totalled 4,597,891. During the same period television licences in West Germany increased by about 160,000 to 3,740,000. During March the number of licensed television receivers in Switzerland increased by some 5,000 to 94,569.

**Mountainous Seas?**—"V.H.F. Field-Strength Measurements over Paths in the Irish Sea involving Mountain Obstacles" is the title of a paper in the March, 1960, issue of the *Proceedings of the I.E.E.*

**Technical Publications Association.**—The office of the Association has been transferred from Brook Street, London, W.1, to 86-88 Edgware Road, London, W.2. (Tel.: Paddington 8001.)

A two-day conference on "The Computing Laboratory in the Technical College" is to be held in the Technical College, Hatfield, Herts., on May 27th and 28th.

**Research Grants.**—Recent awards of grants by the Paul Instrument Fund Committee, composed of representatives of the Royal Society, the Physical Society, the Institute of Physics and the I.E.E., include £6,000 (supplementing a previous grant) to Dr. C. N. Smyth, of University College Hospital Medical School, London, and F. Y. Poynton, of Northampton College of Advanced Technology, London, for the construction of an ultrasonic microscope; £3,000 to Professor D. Gabor and Dr. D. Jones, Imperial College, London, for the development of an electron interference microscope; and £545 (supplementing a previous grant) to Dr. R. Feinberg, Manchester College of Science and Technology, for the construction of an instrument for measuring the intensity of soft X-radiation generated in experimental high-voltage valves.

**R.I.C.**—G. B. Campbell has relinquished the secretaryship of the Radio Industry Council, which he has held since 1956, to allow him to devote his full time to his duties as secretary of Radio Industry Exhibitions Ltd., which was recently formed to organize the Radio Show. Air Marshal Sir Raymond Hart, who was appointed director of the Council just over a year ago, has in addition taken over the functions of Secretary.

**Berlin Radio Show.**—For the first time since 1939 next year's West German Radio Show will be held in Berlin (August 25th to September 3rd). The organizers have for some time been giving consideration to the possibility of making this exhibition international in character but a final decision may rest on the question of reciprocity.

**East German manufacturers** have planned a 50% increase in their production of television receivers this year by comparison with 1959. This will bring the total to 420,000. 85% of the sets to be produced this year will have 17-in tubes, the remainder 21-in tubes. It is understood the majority of receivers will have 90° tubes, although 110° tubes are now in production. It is planned to increase annually the output of receivers until the figure of 1M is reached in 1965.

**Dip. Tech. (Eng.).**—Details of a four-year sandwich course (alternate periods of six months in college and industry) provided by the Bradford Institute of Technology are given in a brochure sent to us by Dr. G. N. Patchett, head of the Department of Electrical Engineering. The course is in electrical engineering but students may specialize in electronics in the final years. The next course begins in October.

**Computer applications** is the general theme of the second annual national conference of the British Computer Society which is to be held in Harrogate from July 4th to 7th. The conference is open to non-members and application should be made to Miss D. E. Pilling, The Electronic Computing Laboratory, The University, Leeds, 2.

**Stable frequency generation** is the theme of a Brit. I.R.E. symposium to be held in the Gustav Tuck theatre, University College, London, on May 25th at 3.0.

**Malvern.**—A lecture-demonstration on quality reproduction from disc and tape will be given by P. Milton, of Goodmans Industries, at the Winter Gardens, Malvern, on May 10th at 7.0.

**Phonetics.**—The proposed international congress on general and applied phonetics which was planned to be held in Hamburg in September to mark the 50th anniversary of the opening of the laboratory of phonetics in Hamburg University, has been postponed. The decision has been reached because of the plans to hold the 4th International Congress on Phonetic Sciences in Helsinki in 1961.

**Non-destructive Testing.**—"How best may the electrical engineer test the quality and endurance of his materials and structures?" is the theme of a conference being organized by the Measurement and Control Section of the I.E.E. for November 8th to 10th next year.

**E.E.A. Council.**—The following member firms (with their representatives' names in parentheses) have been elected to form the council of the Electronic Engineering Association for 1960-61: A.E.I. (V. M. Roberts); A.T. & E. (H. R. A. Wood); Decca Radar (C. H. T. Johnson); E.M.I. Electronics (C. Metcalfe); Elliott Bros. (Col. H. V. Bloodworth); Ferranti (W. D. H. Gregson); G.E.C. (Dr. D. N. Truscott); Kelvin & Hughes (C. G. White); Marconi's W/T (F. S. Mockford); Mullard (R. R. C. Rankin, vice-chairman); Murphy (K. S. Davies); Plessey (P. D. Canning); Pye Telecommunications (J. R. Brinkley) and S.T.C. (L. T. Hinton, chairman).

**International Amateur Conference.**—The Radio Society of Great Britain will act as the host society at the conference of the International Amateur Radio Union, which is to be held in Folkestone from June 13th to 17th. It will be attended by delegations from amateur societies in 15 European countries.

**Correction.**—We have been asked to point out that, due to a typographical error the price of item 35 (Jason Everest 6) in the advertisement of Clyne Radio Ltd. on page 144 of the April issue was given as £3 19s 6d. It should have been £13 19s 6d.

## Personalities

**G. W. Sutton, B.Sc., Ph.D.(Eng.), M.I.E.E.**, has retired from the directorship of A.E.I. Harlow Research Laboratory and is succeeded by **M. E. Haine, D.Sc., M.I.E.E., F.Inst.P.** Dr. Sutton was lecturer in electrical engineering at the City and Guilds College from 1921 until 1930 when he joined Siemens Brothers where he was in charge of the general telephone laboratory until 1942. He was then "lent" to the Ministry of Aircraft Production and at the end of the war joined the Ministry's scientific staff. In 1947, Dr. Sutton was appointed chief superintendent of the Signals Research and Development Establishment of the Ministry of Supply. He rejoined Siemens in 1954 and on the merger with Edison Swan in 1957 became director of the research laboratory of the joint company. Dr. Haine was formerly manager of the Harlow Research Laboratory which, with its associated Blackheath Research Laboratory, now serves the cable, construction, radio and electronic components, and telecommunications divisions of A.E.I. (Woolwich). Dr. Haine joined Metropolitan-Vickers in 1936 and after a period in the high-voltage laboratory transferred to the radio laboratory in 1939 where he worked on the early radar chain project. From 1947 until 1956 he was responsible for the electron physics section of the A.E.I. Research Laboratory at Aldermaston.

**Professor R. Hanbury Brown, I.C.I. Research Fellow** at the Jodrell Bank Research Station from 1949 until this January when he was appointed Professor of Radio Astronomy in the University of Manchester, has been elected a Fellow of the Royal Society "for his many contributions to radio astronomy particularly on galactic and extra-galactic radio emissions." Professor Brown, who is 43, joined Sir Robert Watson-Watt's staff at Bawdsey in 1936 and was from 1942 to 1945 in the Naval Research Laboratory, Washington, as assistant leader of the combined research group working on the development of radar.

**L. Essen, O.B.E., D.Sc., Ph.D., A.M.I.E.E.**, senior principal scientific officer at the National Physical Laboratory, Teddington, has been elected a Fellow of the Royal Society "for his work on the precise measurement of frequency and of the velocity of light." During the past twelve months Dr. Essen has received the Wolfe Award of the D.S.I.R. and also the Popov Medal of the U.S.S.R. Academy of Sciences for his work in this field.

**F.M. in the U.S.A.**—Although for several years f.m. broadcasting in the U.S.A. has been in the doldrums, there is apparently a revival of interest, according to our New York contemporary, *Radio-Electronics*. Whereas in 1957 only about 2% of the domestic receivers sold in the United States included f.m., last year's sales of f.m. and f.m./a.m. receivers were almost 5% of all sets sold. There was also a growth in the number of f.m. stations in operation—about 646 compared with 578 at the end of 1958. A further 157 stations have been authorized for construction.

**Hearing Aids.**—The annual report of the National Institute for the Deaf records that a Joint Advisory Co-ordinating Committee consisting of four nominees of the Institute, one of the Society of Hearing Aid Audiologists and three hearing-aid manufacturers, has been set up under the chairmanship of Air Vice-Marshal E. D. D. Dickson. The committee is considering a code of commercial practice for the hearing-aid industry and the Institute is preparing a list of manufacturers and suppliers who "conform to this code."

A satellite tracking station is to be erected by the United States Government at Kano, the commercial and industrial centre of Northern Nigeria.

Three Insignia Awards by the City and Guilds of London Institute (C.G.I.A.) have been made in recent months to men in the electronics and communications fields. They are **T. J. Morgan, A.M.I.E.E.**, senior executive engineer in the Post Office; **D. A. Rush, Grad.I.E.E.**, project officer for the development of guided missile control systems with Smiths Aircraft Instruments, Cheltenham; and **B. F. Yeo, A.M.I.E.E.**, executive engineer in the Post Office. Except for war-time service in the Royal Signals, the whole of Mr. Morgan's career has been spent with the Post Office, which he joined as a youth in training in 1936 at the age of 18. He is a part-time lecturer in telecommunications economics at the South East London Technical College. Mr. Rush, who is 36, started his career with the Post Office, but since 1946 has been in industry. He was for three years with the Sperry Gyroscope Company before going to Sydney in 1951 to join Amalgamated Wireless Australasia for a short while. On his return he rejoined Sperry where he is concerned with the design of gunfire control systems. He has been with Smiths Aircraft Instruments since 1955. Mr. Yeo, who is 39, has been with the Post Office since 1938. Since 1950 he has been working on electronic developments and national and international telephone switching problems.

**Haraden Pratt**, former telecommunications adviser to President Truman and for some years secretary of the American Institute of Radio Engineers, has received the Institute's 1960 Founders' Award for "outstanding contributions to the radio engineering profession and to the Institute of Radio Engineers through wise and courageous leadership in the planning and administration of technical developments which have greatly increased the impact of electronics on the public welfare." Mr. Pratt started his career as a wireless operator with the Marconi Company in 1906. He retired in 1951 from the International Telephone Corp.

**Dr. Harry Nyquist**, the American consulting engineer whose name is associated with the graphical determination of stability in amplifiers, has been awarded the 1960 Medal of Honour by the American I.R.E. This is the highest annual technical award made by the Institute and is given to Dr. Nyquist for "fundamental contributions to a quantitative understanding of thermal noise, data transmission and negative feedback."

**J. H. Thorp, Ph.D.**, has been appointed sales manager of Semiconductors, Ltd. After graduating with honours from the University of Nottingham he was commissioned in R.E.M.E. in 1941. On demobilization he entered the University of Manchester to do original research and was awarded his Ph.D. in 1948. In the same year Dr. Thorp joined the Armament Research Establishment and in 1950 transferred to what is now the Royal Radar Establishment at Malvern as a senior scientific officer engaged on basic circuit techniques. From 1957 until his present appointment he was with Texas Instruments Ltd.

**N. E. H. Pearson, A.R.C.T.S., A.M.I.E.E.**, who since 1955 has been concerned with broadcast valve development in Siemens Edison Swan (now A.E.I. Woolwich), is appointed sales manager of the cathode-ray tubes and receiving valves product departments of the A.E.I. Radio and Electronic Components Division. Mr. Pearson joined Metropolitan-Vickers in 1926 as a school apprentice. In 1934 he became an efficiency engineer with Ferranti and subsequently joined Hivac where he was chief development engineer until joining Siemens Edison Swan in 1955.

**S. G. Spooner, B.E.M.**, who has been with the Marconi organization since he was 18 and since 1955 has been production manager of Marconi Instruments, is now appointed works manager of that company. After the last war, during part of which he was in the Inter-Services Research Bureau, he returned to Marconi's airborne division at Writtle where in 1948 he took charge of the workshops. From 1951 to 1955 he was superintendent of development and research workshops, Chelmsford.

**W. Pigdon**, who for the past nine years has been general manager of the Wells factory of E.M.I. Electronics, is leaving to become executive vice-president of E.M.I.-Cossor Electronics formed last year in Halifax, Nova Scotia. His duties at Wells are being taken over by Edward Bagley who has been assistant to the engineering director in charge of Ministry work at Hayes for a number of years.

**R. W. Denney, B.Sc.(Eng.), A.M.I.E.E.**, who joined the Ultra organization in 1950, has been appointed chief inspector of Ultra Electronics Ltd. Allan Sadler, M.I.Mech.E., F.R.Ae.S., has joined the company as research and development manager. He was previously manager of the engineering and development laboratories of Smiths Aircraft Instruments Ltd.

The following recent appointments have been announced by Measuring Instruments (Pullin) Ltd.: **D. Bates** becomes production manager in succession to **C. A. P. Cannon**, now assistant to the managing director. Prior to joining M.I.P. last August, Mr. Bates was for ten years with Sifam Electrical Instrument Co. **D. A. Wengaryk**, works foreman for the past seven years, is now chief inspector and is succeeded as works foreman by **E. A. Seeley**, who has been with the company for ten years, latterly as head of the standardization department.

The B.B.C. has recently announced the following engineering appointments: **W. L. Nicoll, A.M.I.E.E.**, as engineer-in-charge of the Kirk o' Shotts television and v.h.f. sound broadcasting station, where he has been assistant e.-in.-c. since the station opened in 1952; **G. Dukes** as engineer-in-charge of the Les Platons television station, Jersey, Channel Islands; and **C. J. Dolan, A.M.I.E.E.**, to the new post of engineer-in-charge (television), Belfast.

**R. B. Young** has joined Airtech, Ltd., as sales manager. Soon after the war he joined the radio division of Standard Telephones & Cables and was engaged on the design of airborne radio equipment. From 1950 until his present appointment he has been with the Plessey Co., in their telecommunications and electronics division.

## OUR AUTHORS

**G. B. Clayton, B.Sc.**, who in the February issue described equipment for demonstrating electron spin resonance, writes in this issue on an analogue computer built at the Liverpool College of Technology where he is lecturer in charge of the electronics section of the Department of Physics and Mathematics. Mr. Clayton started his career as a physics master in a grammar school. This was followed by two years as lecturer in the science department of the Birkenhead Technical College. He joined the staff of the Liverpool College of Technology six years ago and is at present engaged in research in magnetic resonance.

**David R. Birt**, author of the article on page 223, who is 26, is employed in the television applications laboratory of Mullard Research Laboratories, Salfords, and is concerned chiefly with timebase circuits and 625-line circuit techniques. He studied telecommunications engineering for the City & Guilds final certificate, and during his National Service was an instructor at the Radar Training Battalion, Aborfield.

## OBITUARY

**Dr. Edward G. Richardson**, professor of acoustics and reader in physics in the University of Durham, died on March 31st aged 63. From 1923 to 1931 he was a lecturer in physics at his old college, University College, London. He then went to King's College, Newcastle, where he remained as lecturer until 1940 when appointed scientific adviser to the Mine Design Department of the Admiralty. Two years later he accepted a similar appointment at the Royal Aircraft Establishment and subsequently went to Durham University as reader in physics. Professor Richardson, who was very well known and respected in the fields of pure and applied acoustics both in this country and abroad, was editor of *Acustica*, the international journal of acoustics.

## News from the Industry

Colour television receivers earned a profit for the R.C.A. last year for the first time since their introduction in 1954. This is recorded in the Corporation's report for 1959 which also records that sales rose by 19% over the 1958 figure to \$1,395M. Profits increased from \$31M to \$40M. Manufacturing and service for commercial customers accounted for 41% of the Corporation's income, government contracts 34%, the N.B.C.'s sound and television services 23% and radiotelegraph activities 2%. Defence orders increased during the year by 54% to \$470M.

**Simms take over Cawkell.**—Simms Motor and Electronics Corp. have acquired the whole of the issued capital of Cawkell Research and Electronics, Ltd., of Southall, Middx. G. E. Liardet, chairman of Simms and a director of N.S.F., Ltd. (also in the Simms group), will be chairman of the Cawkell company and other directors will be M. A. Hassid, deputy chairman of the parent company and chairman and managing director of N.S.F., J. Ayres (director of N.S.F.), K. G. Smith (deputy managing director of N.S.F.), A. E. Cawkell, who will also be general manager, and R. D. Stafford (works director).

T.C.C. announce a group trading profit during 1959 of £769,725 compared with £528,784 the previous year.

**Telcon Metals Ltd.** is the name of a new company formed by British Insulated Callender's Cables Ltd., to assume responsibility for all the activities of the Metals Division of the Telegraph Construction and Maintenance Co. Ltd. In addition to operating a factory at Crawley, Telcon Metals will control the following subsidiary companies: Magnetic & Electrical Alloys Ltd., Burnbank, Lanarks., Telcon-Magnetic Cores Ltd., Chapelhall, Lanarks., Temco Ltd., Lydbrook, Glos., and Toolpro Ltd., Ilford, Essex. The board of directors of the new company consists of: W. C. Handley (chairman), W. F. Randall (deputy chairman and managing director), Dr. G. A. V. Sowter (commercial director), Dr. H. H. Scholefield (technical director), and D. Norman-Thomas.

**Winston Electronics, Ltd.**, of Shepperton, Middlesex, has become a wholly owned subsidiary of the Dynamics Corporation of America, New York. F. Winston Reynolds will continue as the chairman and managing director, Roger Laurence, director of research and technical director, and Joseph Samuels as works director. Winston Electronics, which was formed in 1950, will be the European manufacturing and sales centre for D.C.A. whose U.S. manufacturing subsidiaries include Reeves Instrument Corp., Anemostat Corp. of America and Radio Engineering Laboratories.

**Pye T.V.T., Ltd.**, has been formed to take over the functions formerly undertaken by the Pye group's Television Transmission Division. The new company will handle television transmission equipment generally and especially its industrial applications. Directors of the new company are C. A. W. Harmer, the Hon. R. N. Frankland, N. A. Twemlow, L. W. Jones and T. G. MacLagan. A board of executive directors has also been formed: A. J. Bennett, L. W. Germany, D. Jackson, E. C. Milton, F. R. Shelton and A. R. Stone.

**Tellux, Ltd.**, who recently moved to 44, Brunel Road, London, W.3, have relinquished their distribution rights of Telefunken receivers (although continuing the distribution of Telefunken valves) and are to market Sony receivers. They will be handling both the Japanese-made sets and those to be manufactured in Eire.

**Siemens and Halske** communications test gear is now being handled in this country by R. H. Cole (Overseas) Ltd., of 2 Caxton Street, London, S.W.1, who have been appointed sole U.K. importers and distributors.

**English Electric Valve Co.** of this country and Eitel McCullough Inc. of the U.S.A., have concluded an agreement for the exchange of technical information and manufacturing know-how over a large range of klystrons, travelling-wave tubes and power tubes.

## EXPORTS

**V.H.F. communication equipment** valued at nearly \$5M has been ordered from Plessey International for the Canadian Army. The equipment is the C42 providing a multi-channel radio-telephone system. Similar equipment, valued at £180,000, has been ordered by the Union of South Africa for its armoured fighting forces.

**"Made in India."**—An agreement has been signed between the Indian government and Marconi's W/T Co. for co-operation in the local manufacture under licence of equipment of Marconi design. The agreement, which provides also for technical assistance and the supply of materials and components, will form the basis for Indian manufacture of equipment in the aeronautical radio, sound and television broadcasting, communications and radar fields.

**Radiotelevisione Italiana**, the Italian broadcasting authority, has placed an order with E.M.I. Electronics for four of the latest television camera channels (Type 203) for use in covering events at this year's Olympic Games taking place in Rome in August.

**Export Licences.**—Further changes and amendments to the Export of Goods (Control) Order 1959 were introduced on March 14th, under amendment No. 3 (S.I. 1960 No. 335). Goods mentioned in the revision include photomultiplier and c.r. tubes, "tracking equipment of a kind using infra-red radiation or ultrasonic waves," telemetering and telecontrol apparatus, c.r. oscilloscopes, and electro-magnetic wave-absorbing materials.

**Anglo-Bulgarian Trade.**—Under a trade agreement for the 12 months ending next March, Bulgaria may purchase £6.3M worth of U.K. goods, including sound radio and television equipment and telegraph communications gear.

**Anglo-Hungarian Trade.**—Sound radio, television and telecommunications equipment is included among the £5.5M worth of British goods which may be imported this year by Hungary, under a new three-year agreement between Hungary and the U.K.

## MAY MEETINGS

*Tickets are required for some meetings: readers are advised, therefore, to communicate with the secretary of the society concerned.*

### LONDON

2nd. I.E.E.—"Planning and installation of the sound broadcasting headquarters for the B.B.C.'s Overseas and European Services" by F. Axon and O. H. Barron at 5.30 at Savoy Place, W.C.2.

3rd. I.E.E.—Discussion on "Teaching and learning machines" opened by C. E. G. Bailey at 5.30 at Savoy Place.

4th. Brit.I.R.E.—"Computer controlled television displays for flight simulators" by J. N. Naish at 6.30 at the London School of Hygiene and Tropical Medicine, Keppel Street, W.C.1.

6th. I.E.E.—Discussion on "Methods of recording measurements—digital or analogue" opened by W. J. Perkins at 6.0 at Savoy Place, W.C.2.

11th. Brit.I.R.E.—"Radio guidance in the automatic landing of aircraft" by J. Shaylor at 6.30 at the London School of Hygiene and Tropical Medicine, Keppel Street, W.C.1.

13th. Television Society.—"The sta-

tus of storage tubes in America" by Dr. R. R. Law at 7.0 at 164, Shaftesbury Avenue, W.C.2.

18th. Women's Engineering Society.—"Electronic weighing" by Miss R. Winslade at 7.0 at 45 Great Peter Street, S.W.1.

19th. I.E.E.—"Technical features of a new television studio at Wembley" by Dr. A. M. Spooner at 6.30 at Savoy Place, W.C.2.

20th. Physical Society.—"Underwater acoustics symposium" at 2.0 in the Physics Department, Imperial College, Imperial Institute Road, S.W.7.

20th. B.S.R.A.—"Sounds of music" by Dr. W. H. George at 7.15 at the Royal Society of Arts, John Adam Street, W.C.2 (postponed from February 19th).

25th. I.E.E.—Discussion on "New semiconductor devices and their possible applications" at 5.30 at Savoy Place.

25th. Brit.I.R.E.—Symposium on "Techniques of frequency synthesis"

at 6.30 at the London School of Hygiene and Tropical Medicine, Keppel Street, W.C.1.

### ABORFIELD

2nd. I.E.E. Graduate and Student Section.—"Silicon transistors—their manufacture and fields of application" by Dr. J. T. Kendall at 7.0 in the Assembly Hall, 3(Tels.) Training Bn., R.E.M.E.

### BIRMINGHAM

2nd. I.E.E.—"Radio aspects of the International Geophysical Year" by Dr. R. L. Smith-Rose at 6.30 at the James Watt Memorial Institute.

### PRESTON

4th. I.E.E.—"Storage and manipulation of information in the brain" by Dr. R. L. Beurle at 7.15 at the N.W.E.B. Demonstration Theatre, Friargate.

### TORQUAY

5th. I.E.E.—"The application of transistors to line communication equipment" by H. T. Prief, D. J. R. Chapman and A. A. M. Whitehead at 3.0 at Electric Hall.



# Self-Balancing Push-Pull Circuits

## I.—Correction to Give Equal Amplitudes in Both Halves of the Load

By D. R. BIRT\*

A push-pull amplifier can be made self-balancing by applying overall push-push negative feedback. The article describes a method of providing this feedback which ensures accurate balance without resort to any close tolerance components.

**A**LTHOUGH a "push-pull" amplifier is an item familiar to most of us, it is as well to agree upon what we mean by this term before embarking on a discourse concerned with the finer points of design of such an amplifier. Let us narrow our thought to the simplest push-pull amplifier, shown in Fig. 1. We may define such an amplifier as one in which the amplification process is shared equally between the two halves (implying that the two "halves" of the amplifier are identical). To make our definition complete, we must state that the grids of the two valves are fed with equal signal voltages in antiphase.

We can see that during the period of the input waveform when the anode current of one valve is increasing, the anode current in the opposite valve is decreasing. This feature is responsible for the term push-pull.

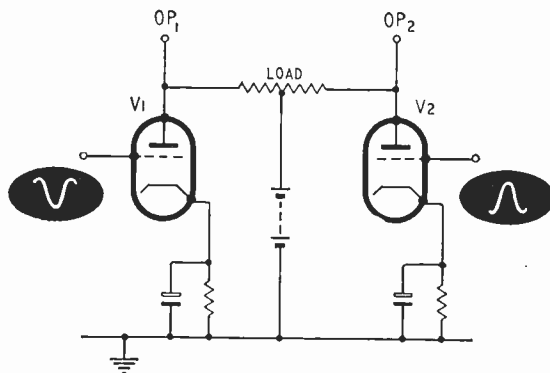

Fig. 1. Basic push-pull amplifier.

The amplifier shown in Fig. 1 is termed balanced, because of its symmetry. If for some reason the amplification is not shared equally between the two valves, we say that the amplifier is unbalanced.

Of the advantages of push-pull operation we may recall, first, that no alternating current of signal frequency flows through the amplifier power supply, thus easing decoupling problems; secondly, that even harmonics unavoidably generated in the amplifier

do not appear in the output<sup>1</sup>. Both these advantages rely upon the amplifier being balanced, particularly if a distributed-load output stage is used<sup>2</sup>. An amplifier circuit arrangement which is automatically self balancing is therefore desirable. The circuit arrangement of Fig. 1 is unsatisfactory in this respect.

To overcome this disadvantage, it is first necessary to obtain an error voltage which is amplitude and phase dependent upon the degree and direction of unbalance. Following normal servo practice, it is then possible to reduce the amplitude of the error voltage by the use of negative feedback, so that the amplifier will maintain a high degree of balance even if the valves and components used in the two "halves" of the amplifier are unmatched.

The advantages of applying this type of feedback appear to have been first realized, may one say inevitably, by A. D. Blumlein in 1936<sup>3</sup>. In British Patent No. 482740, Blumlein describes what has become known as a "long-tailed pair" amplifier. The basic circuit of this form of amplifier is given in Fig. 2. The amplifier has two valves, V1 and V2, which have a common cathode resistance or "long tail,"  $R_3$ , across which is developed the error voltage. The amplifier has a pair of input terminals, to which is applied a push-pull input signal. If the input signal is perfectly balanced about earth, then we know that  $E_1 = -E_2$ . Assuming that V1 and V2 are identical valves, and that the load resistors  $R_1$  and  $R_2$  are equal, there will be a perfectly balanced output from the amplifier at terminals OP<sub>1</sub>, OP<sub>2</sub>. Under these ideal conditions, with the further proviso that V1 and V2 are linear, there will be no a.c. potential across  $R_3$  because the signal currents flowing in  $R_3$  are in antiphase and of exactly equal amplitude. In fact this resistor serves no useful purpose in this case, and merely increases the

Fig. 2. Basic long-tailed pair amplifier.

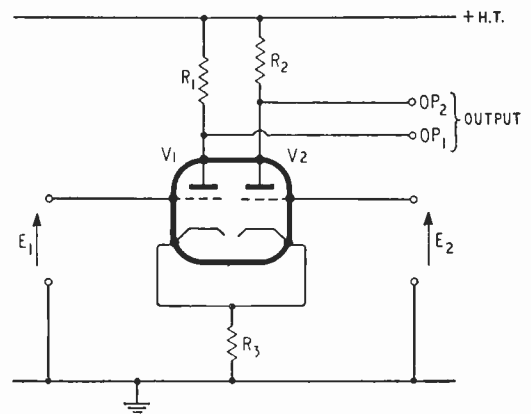

\*Mullard Research Laboratories.

required h.t. line. Provided that a constant anode voltage is maintained, the gain of the amplifier, which may typically be one hundred times, is independent of the value of  $R_3$ . However, in practice, the above ideal conditions could not be realized for any length of time because of valves and component ageing. This is where the common cathode resistance  $R_3$  becomes useful.

To see how this comes about, let us suppose that V1 has a higher mutual conductance than V2. The signal currents flowing in  $R_3$  are  $g_m E_1$  and  $-g_m E_2$ , and in the case we have chosen  $g_m E_1$  is larger than  $-g_m E_2$ , so that an error voltage is developed across  $R_3$  which is in phase with  $E_1$ . If we now consider the grid-to-cathode drive voltages of V1 and V2, we find that the drive to V1 is reduced by the presence of the error voltage. In contrast the drive to V2 is increased, so that the effective gains of V1 and V2 tend to become equalized, and balance restored. This would also have been the case if we had assumed that V2 had a larger mutual conductance than V1, because the error voltage would then have been in phase with  $E_2$ . Clearly the above argument applies if the input signal is not perfectly balanced about earth and  $E_1$  is not equal to  $-E_2$ . In fact, a balanced output can be obtained from the circuit of Fig. 2 when the input signal is completely unbalanced, i.e. when  $E_2$ , for example, is zero. This being so, we may earth V2 grid; and the circuit is now that of a familiar cathode-coupled phase splitter, frequently known as the Schmitt phase splitter<sup>175</sup>.

Since the error voltage is the product of the unbalanced anode current and the resistance of  $R_3$ , it follows that the self-balancing action improves as the resistance of  $R_3$  is increased. Analysis of this circuit<sup>6</sup> also shows that in order to minimise the unbalance of the output voltage, V1 and V2 should have a large mutual conductance and internal anode resistance. The degree of balance is dependent upon the relative values of  $R_1$  and  $R_2$ . It is common practice to adjust the relative values of  $R_1$  and  $R_2$

so that an accurately balanced output can be obtained without an unduly large common cathode resistance. In the completely general case, there is a disadvantage associated with this method of achieving accurate balance in the form of increased sensitivity to unwanted signals (e.g. hum) which are present in equal amplitude at each input terminal and are in phase, or if you like, in push-push. The influence of push-push signals is frequently important, and will be considered later.

### Long-tailed Pair Refinements

Where an accurate balance is required together with symmetry ( $R_1 = R_2$ ) a pentode valve has been used in place of  $R_3$ <sup>7</sup>. In a circuit of this type the a.c. value of  $R_3$  (pentode anode resistance) may be of the order of a megohm, whereas the d.c. voltage developed between V1, V2 cathodes and earth need only be of the order of 50-100 volts. This means that a high impedance is presented to the cathode circuit of V1 and V2 without the large d.c. voltage drop which would be associated with an ordinary resistor.

The presence of a further valve in the common cathode lead of V1, V2 opens up an important possibility. This is the provision of amplified error-voltage feedback. A method whereby this may be provided<sup>8</sup> is shown in Fig. 3.

The feedback loop to V3 grid is effective in improving the balance of the output signal. This may be readily seen from the following argument with reference to Fig. 3. Suppose that the signal at V1 anode is for some reason larger than the signal at V2 anode. Assuming that we make  $R_5$  equal to  $R_6$  a voltage proportional to the unbalance of the output signals will appear at the junction of  $R_5$ ,  $R_6$ . In the case we have chosen, this error voltage will be in phase with the signal at V1 anode, because this is the larger signal. The error voltage is fed to V3 grid. Any signal fed to V3 grid appears amplified, and with a phase reversal, at each of the two output terminals. Thus the error voltage we feed to V3 grid will produce a signal at V1 anode in antiphase to the original excessively strong signal; and at V2 anode a signal in phase with the original weak signal, tending to reduce the unbalance to zero.

The circuit balance is no longer critically dependent upon the relative values of  $R_1$  and  $R_2$ , but rather upon the relative values of  $R_5$  and  $R_6$ .

### Complete Amplifier Balance

By the methods discussed it is thus possible to achieve an accurately balanced signal from an unbalanced input. However, if, as is often the case, a push-pull amplifier contains more than one stage<sup>†</sup>, this is not always of great value, as subsequent stages are likely to introduce unbalance, unless we give them all "long tails." When we come to the output stage, where the valves draw a large current, we find that our "tail" gets very hot! This is undesirable, so let us look now at what happens if we do not provide a large common cathode resistance in the output stage. If the output valves are not matched, we find that it is desirable to compensate for this defect by providing a slightly unbalanced drive.

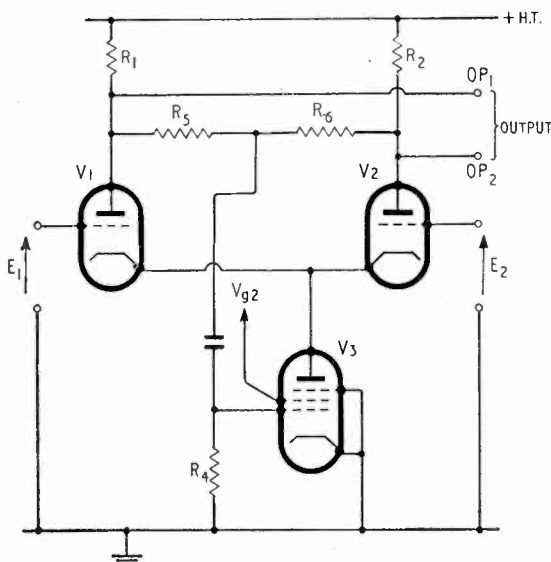

Fig. 3. Long-tailed pair with feedback.

<sup>†</sup> "Stage" here refers to a push-pull stage employing two valves, as in Fig. 1.

By adjusting the unbalance of the drive we can choose between zero even harmonics in the output, or zero fundamental component current in the h.t. line, at one particular signal level<sup>9</sup>; but Nature being as she is, we cannot have both, and either of the above conditions can only be achieved at one signal level!

We want to avoid the necessity of providing a balance control, and we would like our amplifier to remain balanced at all signal levels. It seems logical therefore to provide a push-push feedback loop enclosing the whole amplifier. This idea has been suggested by Offner<sup>10</sup> and is also covered by the Blumlein patent mentioned earlier. However, the idea does not appear to have been fully exploited. Overall feedback may be provided by a simple, but possibly novel, extension of Fig. 3 shown in Fig. 4. Neglecting for the moment even harmonic terms, any unbalance in the amplifier will produce an error voltage of fundamental frequency across the common cathode bias resistor  $R_7$ , which has an amplitude proportional to the degree of unbalance. The phase of the error voltage depends upon the direction of unbalance. This error voltage is reduced by the feedback loop acting via  $V_3$  grid. The important feature is that an excellent balance may be obtained which is not critically dependent on any component values. The degree of valve matching will not now affect the balance of the amplifier, but we shall see that it will influence the harmonic content of the output voltage.

Before discussing this, let us remind ourselves that in a push-pull amplifier even harmonic currents produced by the non-linearity of the output valves cancel by subtraction as far as the load is concerned but are present in the total h.t. current<sup>1</sup>.

First, let us consider that  $V_4$  and  $V_5$  are matched, and therefore produce equal even harmonic currents. We know that these even harmonic currents add together to form part of the total h.t. current. Since this current flows in the common cathode bias resistor  $R_7$ , a harmonic voltage will be developed across  $R_7$ . The feedback loop reduces the amplitude of this sum of the even harmonics by a large factor. The push-pull connection prevents even harmonics from appearing in the output, in the usual way.

However, if the output valves are unmatched, it is likely that they will each contribute a different percentage of even harmonic distortion. Although we are able to reduce the sum of the even harmonics, in the limit to zero, we cannot avoid the fact that the difference between the amplitudes of even harmonics produced by each output valve is not zero. We shall therefore have some even harmonic content in the output of the amplifier, in this case.

### Pentode Output Stage

So far it has been assumed that triodes have been used in the output stage. When this is the case the common cathode current is one and the same

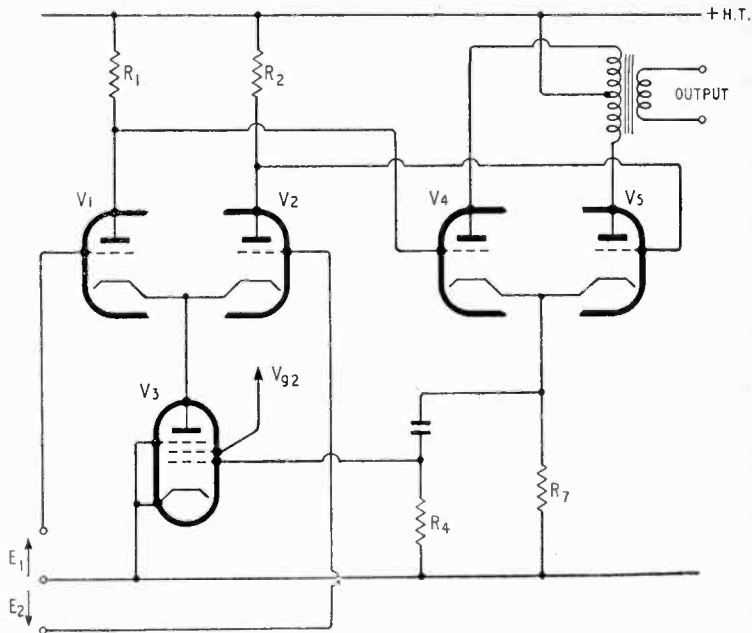

Fig. 4. Amplifier with overall push-push feedback.

thing as the sum of the two anode currents, provided that the valves do not run into grid current. When  $V_4$  and  $V_5$  are pentodes, however, the cathode current is made up of the sum of the anode and screen grid currents. Thus by balancing the cathode currents, we have not necessarily ensured that the anode currents, and therefore the load currents, are balanced. With normal receiving valves, however, the unbalance introduced can only be very small, and may be neglected, provided that the valves are not operated to the extremes of their characteristics.

If in a particular application the screen grid current has a detrimental effect, or the valves draw grid current, a circuit of the form shown in Fig. 5 may be substituted. This arrangement has been simplified to illustrate a principle, rather than provide a working circuit. Naturally we would normally interpose cathode followers between the driver and output valves to supply the grid input power if the valves operate in grid current.

Here the anode currents as such are sampled, and feedback is maintained in the correct sense by changing the connections to  $V_3$ . The new connections to  $V_3$  deserve some further explanation. Let us begin by considering the influence of the suppressor grid potential on the electron stream in the valve. If the suppressor potential is made sufficiently negative, electron flow to the anode ceases. However, the suppressor grid potential cannot influence the cathode current of the valve because it is prevented from influencing the electrostatic field in this region by the screen grid, which we shall assume to be at a constant potential with respect to the cathode. What, then, happens to the electrons we prevented from reaching the anode? The answer is that they alight on the screen grid. We may say therefore that the suppressor potential varies the partition ratio of the anode and screen currents. If the suppressor potential is negative, the greater pro-

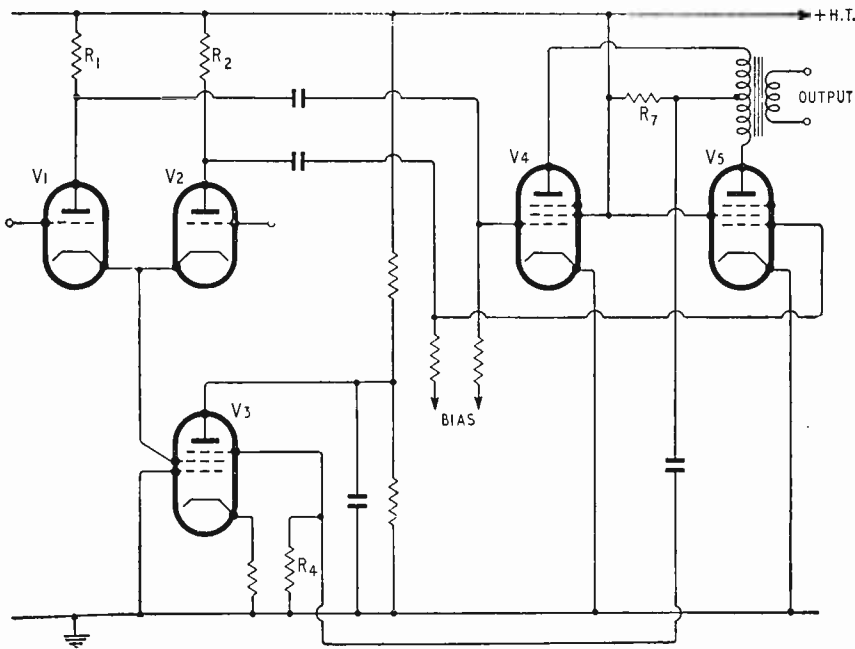

Fig. 5. Alternative feedback circuit

portion of current flows to the screen grid, and as we make the suppressor potential more positive, the greater proportion of current flows to the anode. If the total space current remains constant it follows that for a given change of suppressor potential the change in anode current  $g_{m(g3-a)}$  is equal and opposite to the change in screen grid current  $g_{m(g3-g2)}$ . In a valve such as the 6AS6 this  $g_m$  is approximately 300  $\mu A/volt$ . By connecting the valve in the manner shown in Fig. 5, an error voltage fed to grid 3 produces an in-phase error voltage at the cathodes of V1, V2. This is the condition required for the error voltage feedback to be negative.

Alternative circuits which are a combination of Figs. 4 and 5 may prove useful when there are several push-pull stages preceding the output stage. Where this is the case, particular attention must be paid to the coupling time constants, and also to the impedance of the h.t. supply in determining the stability of the loop.

### Influence of Push-Push Signals

It has been briefly mentioned that the influence of push-push signals is important. This is particularly so, for example, in electro-encephalograph amplifiers. It is of interest to consider the extent to which the circuits described respond to these signals. Broadly they may respond in two ways. First, by providing a push-push output signal. Secondly, by converting an unwanted push-push input signal into a push-pull output signal‡.

Let us consider that the amplifier of Fig. 1 is connected to the receiving end of balanced line subject to electrostatic interference. This is a case where the unwanted signal appears in push-

‡ There is a further aspect of intermodulation between the push-pull input signal and the push-push input signal but this is beyond the scope of this article.

push at the two input terminals. Both V1 and V2 amplify the unwanted signal by equal amounts, so that there will be an amplified push-push interference signal at the output terminals. We may define push-push gain as the ratio push-push output voltage to push-push input voltage. We see that the circuit shown in Fig. 1 has a push-push gain which is equal to its push-pull gain. This is generally undesirable.

However, provided that the circuit is perfectly symmetrical the interference signal will not contribute to the voltage developed between the output terminals, and it is therefore convenient to say that the push-push rejection is infinite.

Now let us consider the circuit of Fig. 2; first, in respect of push-push gain.

Because we are at present considering a linear system, we are justified in considering the behaviour of the circuit to the unwanted signal, without regard to the wanted signal. To this end, the amplifier may be represented in the simplified form shown in Fig. 6, where  $E_3$  represents the unwanted push-push input signal. It can now be readily seen that  $R_3$  provides negative current feedback in this case. The circuit of Fig. 6 bears a remarkable resemblance to a concertina phase splitter. Indeed we may use this similarity to tell us that if  $R_2/2 = R_3$ , the gain of the amplifier to the unwanted signal will be of the order of 0.9, which is low compared with the amplification of the wanted signal of 100 times. The inclusion of  $R_3$ , therefore, provides discrimination between push-pull and push-push signals by reducing the amplitude of the push-push output by negative feedback. This is not really surprising, because the balance error voltage we were considering earlier could be regarded as a

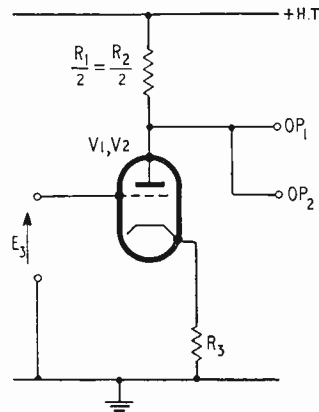

push-push signal. In Fig. 2, if  $R_1$  is equal to  $R_2$  and V1 and V2 are identical, then once again the push-push rejection will be infinite. However, if  $R_1$  is not equal to  $R_2$  there will be a component of the interference signal in the output voltage between terminals  $OP_1$  and  $OP_2$ .

Fig. 6. Long-tailed pair equivalent for push-push signal.

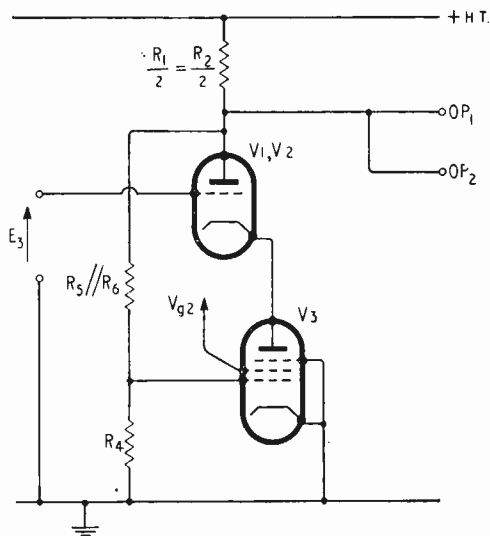

Fig. 7. Circuit of Fig. 3 simplified for push-push operation.

Now let us consider the circuit of Fig. 3, which is redrawn in Fig. 7 to show its operation under push-push drive conditions more clearly. If  $R_4$  is made much larger than  $R_5$  and  $R_6$  in parallel, then as far as push-push signals are concerned, the circuit is that of a cascode amplifier with very nearly 100% feedback. The effect of the additional feedback loop to  $V_3$  grid is to further reduce the output of the unwanted signal.

We may conclude that the self balancing systems considered also enhance this aspect of amplifier performance.

To summarise, the balance of a push-pull amplifier can be stabilized to provide equal amplitude signal currents in each half of the load at all signal levels, and at all frequencies handled by the amplifier, by applying overall push-push feedback in the manner shown in Fig. 4. The effect of component tolerances on balance is reduced by this means, and the push-push gain is greatly reduced. The amplitude of signal and harmonic currents

flowing in the h.t. supply is reduced, thus easing decoupling problems; but the amplitude of even harmonics in the output is only zero if the valve curvatures are matched.

Although a.c. couplings have been shown, there is no reason why d.c. couplings should not be used, if these are required.

The characteristics of this type of amplifier make it useful as a differential amplifier, that is, an amplifier which responds to the difference between two input signals, irrespective of the individual input levels. It is also useful where a stable and accurate balance is required, or where a large-amplitude unwanted push-push signal (e.g. hum) is present at the input. It is also possible that some benefit may be obtained by applying feedback of this type to a "Phantom" amplifier<sup>11</sup> to reduce cross-talk between push-push and push-pull channels at the expense of gain in the push-push channel.

(To be concluded)

## REFERENCES

- <sup>1</sup> "Radio Engineering" by F. E. Terman, Sec. 6-11, p. 299.
- <sup>2</sup> "Amplifiers and Superlatives." D. T. N. Williamson and P. J. Walker, *Wireless World*, Sept. 1952, Vol. 58, p. 357.
- <sup>3</sup> British Patent No. 482740, Application Date 4.7.36, A. D. Blumlein.
- <sup>4</sup> "Cathode Phase Inversion". O. H. Schmitt, *Journal of Scientific Instruments*, March 1938, Vol. 15, p. 100.
- <sup>5</sup> "Phase Splitting in Push-Pull Amplifiers." W. T. Cocking, *Wireless World*, April, 1939, Vol. 44, p. 340.
- <sup>6</sup> "Push-Pull Input Circuits." W. T. Cocking, *Wireless World*, May, 1948, Vol. 54, p. 183.
- <sup>7</sup> "Electro-Encephalograph Amplifier." D. L. Johnston, *Wireless Engineer*, Aug/Sept/Oct, 1947, Vol. 24, pp. 231, 271 and 292.
- <sup>8</sup> "Balanced Output Amplifier of Highly Stable and Accurate Balance." Communication from E.M.I. Ltd., *Electronic Engineering*, June, 1946, Vol. 18, p. 189.
- <sup>9</sup> "Push-Pull Balance." W. T. Cocking, *Wireless World*, 1947, Vol. 53, p. 408.
- <sup>10</sup> "Push-Pull Resistance Coupled Amplifiers." F. Offner, *Review of Scientific Instruments*, 1937, Vol. 8, p. 20, Figure 4.
- <sup>11</sup> "Single Amplifier Stereo." Technical Notebook, *Wireless World*, Feb. 1959, Vol. 65, p. 80.

## BOOKS RECEIVED

**Television in Science and Industry**, by V. K. Zworykin, E.E., Ph.D., D.Sc., E. G. Ramberg, Ph.D., and L. E. Flory, B.S. Wide survey of the present and possible applications of closed-circuit television with a technical assessment of the advantages of alternative systems. Pp. 300; Figs. 208. Price 80s. John Wiley & Sons, Inc., available from Chapman & Hall, 37, Essex Street, London, W.C.2.

**Analysis of Linear Systems**, by David K. Cheng. Advanced treatise on the formulation and solution of linear differential equations relating to problems in physics, electrical and mechanical engineering, with special reference to the use of Laplace transformers. Pp. 431; Figs. 263. Price \$8.50. Addison-Wesley Publishing Co. Inc., Reading, Mass., U.S.A., or from Pergamon Press, Ltd., 4, Fitzroy Square, London, W.1.

**Magnetic Sound Recording**, by D. A. Snell. Philips Technical Library handbook on the theory and practice

of tape recording with hints on microphone techniques and chapters on possible applications. Pp. 230; Figs. 162. Price 25s. Cleaver-Hume Press, Ltd., 31, Wright's Lane, London, W.8.

**Shortwave Propagation**, by Stanley Leinwoll. A lucid and concise description of ionospheric forecasting with details of how MUF curves are prepared and a summary of the conditions on each of the amateur bands during summer and winter and at the equinoxes. A global time conversion chart is included as an insert. Pp. 160; Figs. 75. Price \$3.90. John F. Rider Publisher Inc., 116, West 14th Street, New York, 11.

**R.S.G.B. Amateur Radio Call Book**. 1960 list of amateur transmitters in Great Britain and Eire, including stations licensed to transmit television. Pp. 60. Price 3s 6d or 4s by post from the Radio Society of Great Britain, New Ruskin House, Little Russell Street, London, W.1.

# Technical Notebook

**Multi-Section Semiconductor Devices**, unlike multiple valves, are rather unusual. In 1959 *I.R.E. National Convention Record, Part 1—Audio, Broadcast and Television Receivers, Broadcasting*, D. Thorne and R. V. Fournier describe a diode-“triode” transistor assembly for use in broadcast-band receivers to provide detection, a.f.-amplification and

of about 70. In operation, the signal is demodulated by the diode and direct coupled into the transistor base, through the base material. Due to the direct coupling, the diode d.c., as well as the a.f., influences the transistor emitter current; thus amplified a.g.c. may be derived from the potential developed across the emitter resistor. The amplified a.f. is extracted, in the usual way, by a load in the collector circuit.

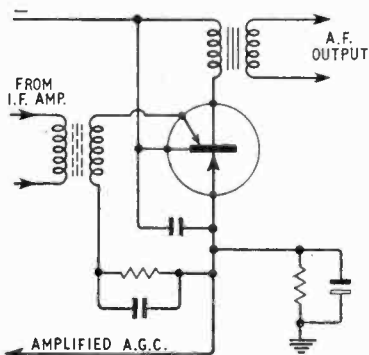
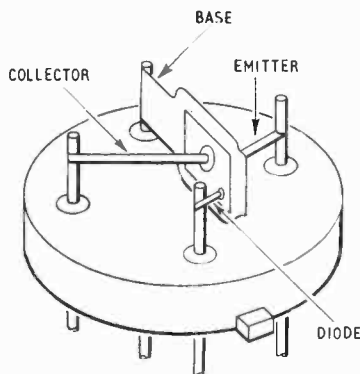

amplified-a.g.c. facilities. A simplified circuit diagram of a typical application of the device is shown above; it will be seen that it resembles fairly closely a similar valve circuit (see, for instance: p. 1113, *Radio Designer's Handbook* (9th Edn.) by F. Langford-Smith, Iliffe, 1957). The diode is formed as an alloy junction on the collector side of the transistor base (see sketch), and is separated from the transistor by sufficient distance to avoid interaction between them (other than by the direct coupling via the common base). The transistor is a typical alloy-junction unit with a  $\beta$

**Semiconductive Plastics** are described in *Electronic News* for 11 January and 8 February, 1960. Developed in the U.S.S.R. and at Princeton University, U.S.A., they depend for their electrical functioning on the reduction of the distance between the ring-molecule structures of aromatic compounds by the formation of molecular bonds between the carbon atoms of adjacent rings: this allows charge transfer to take place from one molecule to the next. At Princeton the “joining together” of hydroxy-anthracene molecules has been accomplished with phthalic anhydride, and experiments on doping with aluminium and nickel are being carried out. Resistivities ranging from  $10^{-2}\Omega/\text{cm}$  to higher than  $10^7\Omega/\text{cm}$  have been achieved. The Russians have worked with polymers of acrylonitrile made by the use of organo-metallic catalysts and ionically initiated polymers irradiated with X-rays. Doping was carried out by immersion in solutions of metallic salts, which are absorbed into the polyacrylonitrile. A sample doped with copper gave a resistivity of  $10^{-2}\Omega/\text{cm}$  at  $300^\circ\text{C}$ .

**Constant-Output-Impedance Attenuator** developed by Electronic Instruments has its design based on the fact that the output impedance of a two-resistor potential divider is equal to the reciprocal of the sum of the two conductances of the resistors. In

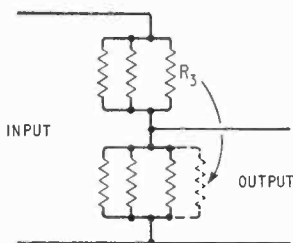

this attenuator (shown schematically in the diagram), the sum of these two conductances, and thus the output impedance, is kept constant by making-up each of the two divider resistor arms out of a number of resistors in parallel and switching these parallel resistors from one arm of the potential divider to the other to alter the attenuation. (For example, the resistor  $R_3$  may be switched to occupy the dotted position.) This is equivalent to switching conductances from one arm to the other and thus keeps the sum of the two arm conductances constant.

**Microwave Coaxial Transistor** of the mesa type, and a very wide band microwave amplifier making use of it, have been developed at Bell Telephone Laboratories. The transistor has a p-n-p diffused-based, alloyed-emitter structure and is designed for use as an oscillator at  $3\text{Gc/s}$ , or as an amplifier at  $1\text{Gc/s}$  and below. The mesa is only 1.8 mils long, and 1.5 mils wide. Three metal “stripes,” each 0.3 mil wide by 1.5 mils long, are evaporated on to the surface of the plateau and alloyed into the semiconductor. Gold wires 0.2 mil in diameter are used for making connections. The diffused base is only 0.02 mil thick. Since conventional encapsulating methods would introduce too much parasitic capacitance and inductance, the transistor is mounted in a coaxial shell which electrically matches a  $50\Omega$  coaxial line. The germanium wafer is gold bonded to the inner conductor of the output section; the emitter “stripe” is connected to an internal shield integral with the encapsulation shell; the base “stripes” are connected to the centre conductor of the input line. The three-stage amplifier, constructed on transmission-line principles, has a gain of 18dB, flat within 1dB from below  $1\text{Mc/s}$  to over  $750\text{Mc/s}$ . Higher gain, with correspondingly lower bandwidth, can also be achieved. In the amplifier the emitter is earthed in order to maintain outer-conductor continuity, and the transistor biases are stabilized with d.c. local shunt feedback. A low-frequency transistor is inserted in each biasing circuit to increase the feedback at d.c. without wasting appreciable amounts of high frequency gain. The amplifier is said to have excellent stability, and the noise figure measured at  $200\text{Mc/s}$  is 5.5dB with the feedback loops open.

**Semiconductor Bullet-in.**—An unusual method of testing the shock-resistant properties of semiconductor rectifiers, tried by the International Rectifier Corporation, has been to fire them out of a shotgun into a telephone directory. Apparently, penetration up to page 772 has been achieved. We are now waiting to hear of the first grouse to be bagged by a p-n junction.

# Simple Analogue Computer

INEXPENSIVE INSTRUMENT CONSTRUCTED FOR DEMONSTRATION PURPOSES

By G. B. CLAYTON,\* B.Sc.

**T**HE electronic analogue computer has in the last few years become an important tool for the engineer, physicist, and applied mathematician. While it is not capable of the accuracy of a digital computer it is nevertheless extremely useful for the analysis of many practical dynamical systems, its accuracy usually exceeding that of the known input data. Further, the analogue computer requires no specialist knowledge of computer programming techniques, an analysis of a physical system being carried out by setting up a direct electrical equivalent of the system. The physical variables of the system are represented by voltages which are made to vary in exactly the same way as the physical quantities. This method of analysis enables a greater insight of the dynamical behaviour of the system to be acquired.

The most important components of an electronic analogue computer are d.c. amplifiers, which are made to sum and integrate by the connection of suitable feedback and input impedances. A good many analogue computers are commercially available, ranging from desk-top instruments, using only a small number of amplifiers, to large complex installations using over a hundred amplifiers.

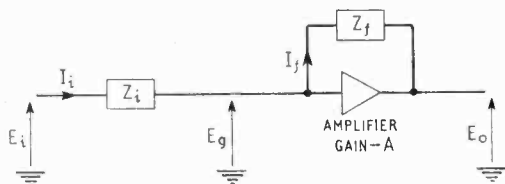

Fig. 1. Basis of the operational amplifier used in the analogue computer.

The author required a small computer suitable for introducing students to computer techniques and for demonstrating some of the many computer applications. Accuracy of solution was not of primary importance and it was therefore felt that the purchase of a commercial instrument was uneconomical. By simplification and the use of "surplus" components it has been found possible to build a small computer that performs very satisfactorily at a small fraction of the cost of a comparable commercial instrument. This article will first outline the basic theory of electronic analogue computers and will then describe the equipment constructed. A subsequent article will give an example of its use.

**The Operational Amplifier.**—Consider an amplifier whose gain  $-A$  extends down to zero frequency and whose output terminal is arranged to be at earth potential when its input terminal is earthed. The negative sign indicates that the amplifier is phase reversing, i.e. if its input ter-

minal were made  $x$  volts positive with respect to earth its output terminal would become  $Ax$  volts negative with respect to earth. Let a feedback impedance  $Z_f$  and an input impedance  $Z_i$  be connected as shown in Fig. 1, and assume the amplifier draws no current at its input grid and that its output impedance is negligibly small compared with  $Z_f$  and  $Z_i$ . If the gain of the amplifier is very large its input will differ very little from earth potential even when it is giving its maximum output. As an approximation the input grid may be thought of as always being at earth potential, and using this approximation one has

$$I_i = \frac{E_i}{Z_i} \quad \text{and} \quad I_f = -\frac{E_o}{Z_f}$$

But the amplifier draws no current at its input grid, and therefore  $I_i = I_f$ .

$$\text{This gives } E_o = -\frac{Z_f}{Z_i} \cdot E_i \quad \dots \quad (1)$$

If the impedances are made equal resistances,  $Z_f = Z_i = R = 1 \text{ M}\Omega$ , say, then  $E_o = -E_i$  and the amplifier acts as a sign changer, or more generally

with unequal resistances  $E_o = -\frac{R_f}{R_i} \cdot E_i$ , and the amplifier multiplies by the constant coefficient  $-\frac{R_f}{R_i}$ .

Normally  $R_f$  is held constant at  $1 \text{ M}\Omega$  and  $R_i$  is changed when necessary. If the input impedance is made a resistor and the feedback impedance a capacitor then  $Z_i = R_i$  and  $Z_f = \frac{1}{j\omega C} = \frac{1}{P \cdot C}$

$P$  is the differential operator  $\frac{d}{dt}$  and we use the

equality  $j\omega = P = \frac{d}{dt}$  which is quite common in electrical engineering. Substitution in equation (1) gives:

$$E_o = -\frac{1}{CR_i} \cdot \frac{1}{P} \cdot E_i = -\frac{1}{CR_i} \int_0^t E_i dt$$

The amplifier integrates and multiplies by  $-\frac{1}{CR_i}$ .

With  $C = 1 \mu\text{F}$  and  $R = 1 \text{ M}\Omega$ ,

$$E_o = -\int_0^t E_i dt$$

So far only one input voltage has been considered. The operational amplifier may, in fact, be used with several input voltages, each voltage being connected to its own separate input impedance. Consider the amplifier of Fig. 1 connected to  $n$

\*Liverpool College of Technology.

inputs as shown in Fig. 2. For large amplifier gain the approximation  $E_g = -\frac{E_o}{A} \approx 0$  is again used, giving:

$$I_1 = \frac{E_1}{Z_1}, I_2 = \frac{E_2}{Z_2}, \dots, I_n = \frac{E_n}{Z_n}, \text{ and } I_f = -\frac{E_o}{Z_f}$$

The amplifier draws no current at its input grid, and therefore:

$$I_f = I_1 + I_2 + \dots + I_n$$

This gives:

$$E_o = -\left[ \frac{Z_f}{Z_1} \cdot E_1 + \frac{Z_f}{Z_2} \cdot E_2 + \dots + \frac{Z_f}{Z_n} \cdot E_n \right]$$

If the feedback and input impedances are all resistances then:

$$E_o = -\left[ \frac{R_f}{R_1} \cdot E_1 + \frac{R_f}{R_2} \cdot E_2 + \dots + \frac{R_f}{R_n} \cdot E_n \right]$$

The input voltages are multiplied by constant coefficients and then added together. The amplifier output gives the value of this sum with its sign changed. Normally  $R_f$  is made equal to  $1M\Omega$  and the input resistances are chosen to give the desired coefficients.

If the feedback impedance is made a capacitor and the input impedances are all resistances:

$$Z_f = \frac{1}{P \cdot C}, Z_1 = R_1, Z_2 = R_2, \dots, Z_n = R_n$$

Then

$$E_o = -\left[ \frac{1}{CR_1} \cdot \frac{1}{P} \cdot E_1 + \frac{1}{CR_2} \cdot \frac{1}{P} \cdot E_2 + \dots + \frac{1}{CR_n} \cdot \frac{1}{P} \cdot E_n \right]$$

or

$$E_o = -\left[ \frac{1}{CR_1} \int_0^t E_1 dt + \frac{1}{CR_2} \int_0^t E_2 dt + \dots + \frac{1}{CR_n} \int_0^t E_n dt \right]$$

and the operational amplifier acts as a summing integrator.

The need often arises for multiplication by some

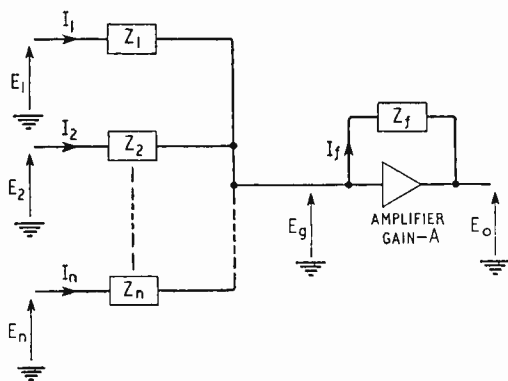

Fig. 2. The operational amplifier of Fig. 1 connected to a number of input voltages.

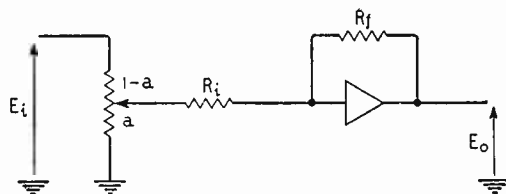

Fig. 3. Potentiometer used for multiplication by a constant.

easily changed constant. This is most conveniently accomplished by the use of a simple potentiometer (Fig. 3). In this circuit  $E_o = -a \frac{R_f}{R_i} E_i$

This equation neglects the error introduced by the loading of the potentiometer. The error may be calculated or alternatively "a" may be set with the potentiometer on load. A further requirement is provision for setting initial values of the variable voltages. These "initial conditions," as they are called, are usually set before the start of a computer "run" as voltages across the feedback capacitors of the integrating amplifiers.

Provision for carrying out all the above operations has been included in the apparatus to be described. A more elaborate arrangement would probably include function generators and provision for multiplication by variables.<sup>1</sup>

**Construction of Apparatus.**—The apparatus consists essentially of five amplifiers, two of these being used as integrators or summing integrators, the other three as summers or sign changers. Amplifier input and output sockets are mounted on a panel. Short lengths of wire plugged into these sockets enable the connections between amplifiers necessary for the solution of a particular problem to be easily made. The fixed input and feedback impedances are mounted behind this panel, together with coefficient and initial-condition setting potentiometers. The amplifiers and front panel are mounted on top of the power supplies; these are commercially built stabilized supplies. The general layout of the apparatus should be clear from the photographs Figs. 4 and 5.

The gain of an amplifier used in an analogue computer must extend down to zero frequency, and this means that direct coupling must be used between the individual stages of the amplifier. This direct coupling introduces problems in the design procedure that are peculiar to this type of amplifier. The basic design considerations are:

(a) Interstage coupling techniques. Correct quiescent bias voltages must be placed on all grids, and this usually involves the use of resistive coupling dividers and extra negative power supplies.

(b) Balancing adjustment. It is necessary to provide a means of adjusting the output voltage to its desired quiescent level (usually earth potential) when the input is at zero signal level.

(c) Stability. Any small drift in the quiescent voltage levels in the first stage of a high-gain d.c. amplifier can result in a considerable change in the output level of the amplifier. Drift in the quiescent voltage levels may usually be attributed to one or more of the following causes: (1) small changes in the grid current flowing through the grid circuit

(Continued on page 231)



impedance; (2) variations in heater voltage which cause changes in the initial emission velocities of the electrons and so produce a change in the steady current through the valve; (3) variations in supply voltages; (4) changes in the value of circuit components and ageing of valves.

The above difficulties may be largely overcome by the use of a suitable circuit arrangement. All power supplies for use with d.c. amplifiers should, of course, be well stabilised. The reader is referred to the literature for a full treatment of the problems involved in the design of d.c. amplifiers.<sup>2</sup>

The d.c. amplifiers used by the author were chosen primarily for their simplicity. They use only one valve type and two power supplies. The circuit is illustrated in Fig. 6. This circuit was originally developed for computer use at the University of Michigan<sup>3</sup>. The first stage uses a double triode connected as a cathode-coupled amplifier, this method of connection giving some compensation for variations in heater and supply voltages.

A cathode-coupled amplifier may be thought of as a cathode follower driving an earthed-grid amplifier. Cathode followers and earthed-grid amplifiers are both non phase-inverting stages, so the output from this first valve will be in phase with the input voltage. This output is directly coupled to the next valve by a resistive coupling divider. The resistances in this divider are chosen so as to put the correct quiescent bias on the grid of the next stage.

Adjustment of this bias is provided by the 500kΩ potentiometer, which serves as a balance control. Balancing the amplifier consists of connecting its input terminal to earth and adjusting this potentiometer to bring the output terminal of the amplifier to earth potential. This balancing operation has to be performed periodically to cancel out the effect of any small drift in the output level of the first stage. Drift would otherwise cause the amplifier to show an output even though its input were zero. Only a very small adjustment of the potentiometer is required and a value of 500kΩ is, in fact, rather large for the purpose. This value was used to give a greater tolerance for the values of the two resistances used in the coupling divider. The original circuit used a 50-kΩ potentiometer for the purpose. It was found to give a finer control but made the selection of the coupling resistance values rather critical.

The second valve of the amplifier is also a double triode. The first half of it is used as a normal voltage amplifier and the second half as a cathode follower to give the amplifier a low output impedance. The

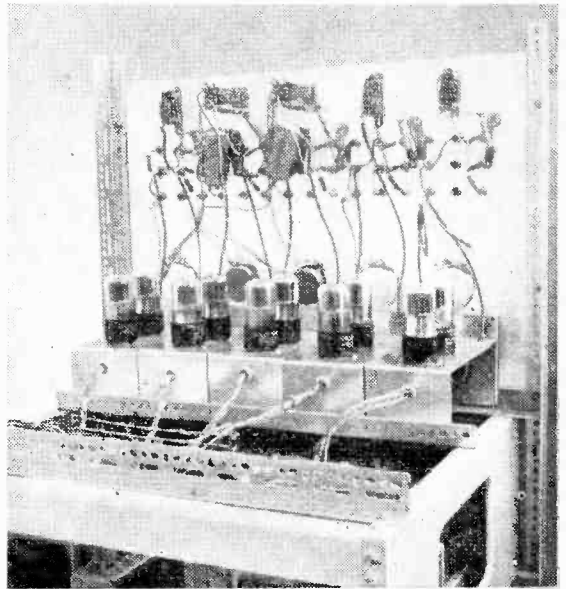
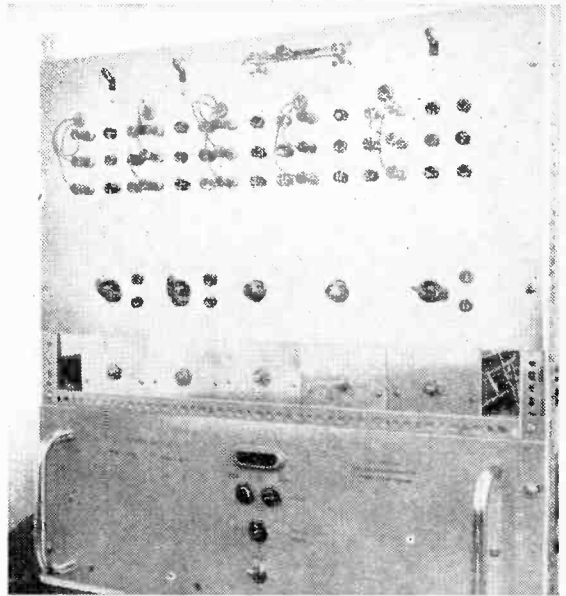

Top Right: Fig. 4. Front panel of the analogue computer, showing the connection sockets at the top and the five smaller panels of the d.c. amplifiers in the centre.

Centre Right: Fig. 5. Rear of the analogue computer, again showing the group of d.c. amplifiers, each on a small individual chassis.

Right: Fig. 6. Circuit of the d.c. amplifier used in the computer.

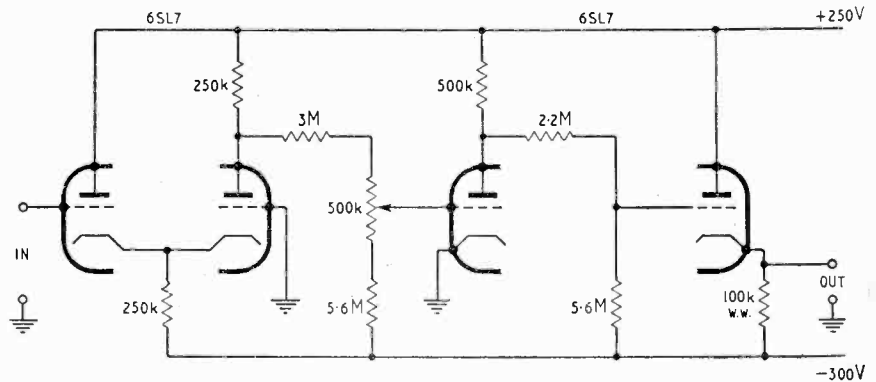
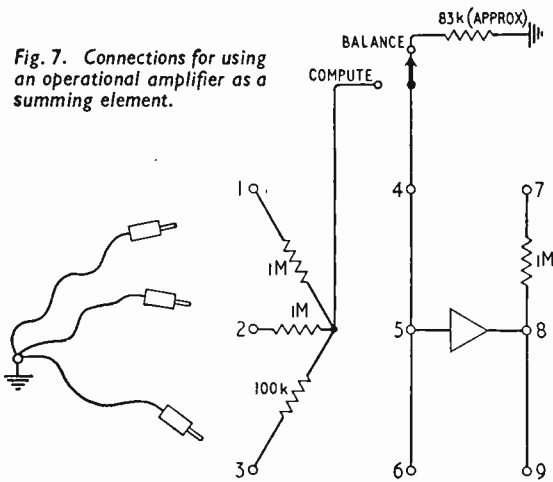

Fig. 7. Connections for using an operational amplifier as a summing element.



to earth. Sockets 4, 5 and 6 connect directly to the amplifier input. A 1-MΩ feedback resistor is connected between sockets 7 and 8 and is joined to the amplifier input by an external loop. The switch allows the amplifier input to be disconnected from any incoming signals and earthed through a resistor equivalent to the parallel combination of the three input resistors. In this position of the switch the amplifier balance control is adjusted to bring the amplifier output to earth potential. An external meter is needed for this balancing operation.

Fig. 8 shows the arrangement for the amplifiers operated as summing integrators. It differs from Fig. 7 in that feedback is through a capacitor. A 0.1μF and a 1μF capacitor are provided, the particular value required being selected by an external loop. A three-position ganged switch enables selection of "compute," "balance," and "reset" conditions. In the "compute" position, sockets 1, 2 and 3 connect to the amplifier input through the fixed input resistors, and again if a particular input is not in use it is earthed. In the "balance" position the amplifier input is connected to earth through a resistor equal to the parallel combination of the three input resistors. In the "reset" position the amplifier is lifted out of circuit and the desired initial voltage is set across the feedback capacitors. This voltage is controlled by means of the initial-condition setting potentiometer and is derived from an isolated battery supply (a grid bias battery has been used). The control switches for the two integrators are ganged together.

Coefficient-setting potentiometers are mounted on the front panel. Each is provided with two sockets (Fig. 9). The coefficients are set with the potentiometer on load by the use of a dry battery and valve voltmeter.

Next month the use of the computer to represent a simple mechanical system will be described.

#### REFERENCES

- 1 "Electronic Analog Computers," by G. A. Korn and T. M. Korn, 2nd Edition, McGraw-Hill, New York, 1956.
- 2 "Vacuum Tube Amplifiers," by G. E. Valley and H. Wallman, M.I.T. Radiation Laboratory Series, McGraw-Hill, New York, 1948.
- 3 *Rev. Sci. Instr.*, 21, 154, 1950.

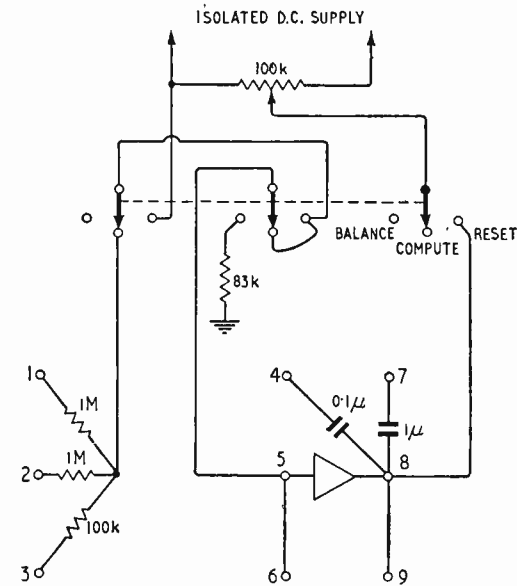

Fig. 8. Connections for using an operational amplifier as a summing integrator.

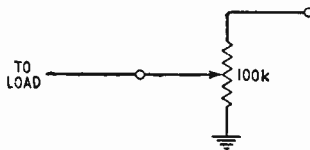

Fig. 9. Coefficient-setting potentiometer

complete amplifier is phase reversing since it has only one phase reversing stage.

Each operational amplifier in the computer is provided with nine sockets on the front panel. Fig. 7 shows the arrangement for the amplifiers operated as summers. Signals to be added are connected into sockets 1, 2 and 3, when they go through the fixed input resistors. These resistors are high-stability carbon types specially selected to be as close as possible to their quoted values. If any one of the sockets is not in use it is connected

## Technical Colleges

THE need for closer co-operation between technical colleges and industry—to their mutual benefit—in the further education of trainees has been stressed from time to time both at Government level and by educationists. Now an appraisal of the present situation, with recommendations for improving the relationship between colleges and industry has been made by the Federation of British Industries. The 44-page booklet "The Technical Colleges and their Government" is issued in the hope that it will "stimulate industrialists to serve [on college governing bodies] and lead Local Authorities so to order the constitutions and procedures of their governing bodies that service is a really worth while task".

The government of technical colleges is considered from the industrial standpoint and the present position is viewed against the background of the rapidly changing needs of industry. The booklet is issued by the joint F.B.I. Technical College Committee and copies are obtainable from the F.B.I., 21 Tothill Street, London, S.W.1.

# h

By "CATHODE RAY"

## THE MEANING OF COSH, SINH AND TANH

If your school teacher explained clearly to you what algebra was in aid of, so that you were able to start with the encouraging thought that you were going to learn something worth knowing, you were lucky. Mine didn't, so it was quite a time before it made sense, and by then I was well behind. (You may think I still am.) However, that hurdle having at length been surmounted, I don't remember that it was ever necessary for anyone to justify to me the existence of trigonometry. Angles come into everyday life so much that even politicians are aware of them and often claim to be approaching things from them. The natural tendency is to estimate

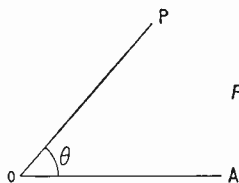

Fig. 1. A typical angle,  $\theta$ .

angles not by the amount of turning (which is difficult) but by the ratio of two distances. So it is obviously helpful to have names for the several different ratios that can be used. There is no difficulty in finding lots of everyday examples of the convenience of thinking in terms of sines, cosines, etc. Then when we have studied a.c. to even a slight extent we wonder how we could ever do without them.

If we pursue the study of communications beyond a fairly elementary stage we are likely to encounter the same names with "h" tacked on. This, we are told, stands for "hyperbolic"; and the relationship of the functions so named to the rectangular hyperbola is analogous to that of the trigonometric functions to the circle. No doubt that statement is duly explained and illustrated at the beginning, but if at the end of it you can face pages of formulae embodying "cosh", "sinh", "tanh", etc. without misgivings, you were again more fortunate than I in your teachers or brain power or both, and have no business to be reading this. I am assuming that you are an ordinary person, to whom the importance and significance of a circle and a circular angle are clear in a way that those of a rectangular hyperbola and hyperbolic "angle" are not. And that while you can easily see that the intensity of sunlight received on level ground is (other things being equal) proportional to  $\sin \theta$ , where  $\theta$  is the angle of elevation of the sun, you find the statement "cosh  $a = 1 + Z_1/2Z_2$ ", where  $a$  is the attenuation constant of a filter and  $Z_1$  and  $Z_2$  the series and shunt impedances of the sections, less evident.

This is only to be expected. The keenest hyperbolic enthusiast could hardly deny that the circle is

closer to daily life than the hyperbola, and that whereas anyone would be hopelessly handicapped in almost any science or technology without circular functions he can go quite a long way without hyperbolic functions. But certain subjects within *Wireless World* scope, notably filters and lines, are thick with them. So we will do well to rid ourselves of any dread of the cosh. One possible policy, of course, is to take the formulae on trust, and when calculations are necessary, just look up the values in tables. To adapt a classic remark by E. K. Sandeman, "the fact that they are called hyperbolic functions does not make the tables any more difficult to use".

But that is not very satisfactory. One should know *why*. What I'm going to try to show is that there is a mathematical structure of which we are familiar with the "front elevation" (namely, trigonometry, or circular functions) but have not seen the "end view" (hyperbolic functions) or have failed to grasp its relationship to the front view. This "blueprint" analogy is not altogether fanciful, as we shall see. And the shapes of the two views are more alike than in most working drawings.

First let us take a good look at the view we know. In Fig. 1 we have a specimen of an angle, denoted by the customary symbol  $\theta$ . Another familiar way of referring to it is by means of capital letters; for example, AOP. This angle is the amount of turning needed to take a straight line from the position OA to OP. An obvious unit of turning, and therefore, of angle, is one complete revolution. This, for some reason which I used to know, was divided into 360 equal parts called degrees. The usual zero for angles is the three o'clock direction, presumably because it lies along the positive X axis in co-ordinates; and anticlockwise rotation is regarded as positive.

Direct measurement of angle, without bringing in

Fig. 2. One measure of the angle is the ratio  $AP/OA$ ; another is the area (shaded) swept by OP in rotating through the angle.

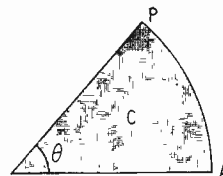

any lengths, is quite a problem. In practice, as I said, angles are reckoned as ratios of two lengths. The vertical angle of a road or railway, better known as its gradient, is specified in this way; for example, 1 in 4, meaning that  $\sin \theta = \frac{1}{4}$ . Although the sine or some other trigonometrical ratio is often convenient for measuring an angle or the effect of an angle, it has the disadvantage that the angle is not directly proportional to it, so tables have to be used. The only lengths, the ratio of which is proportional

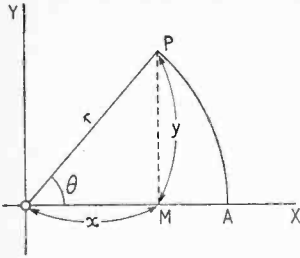
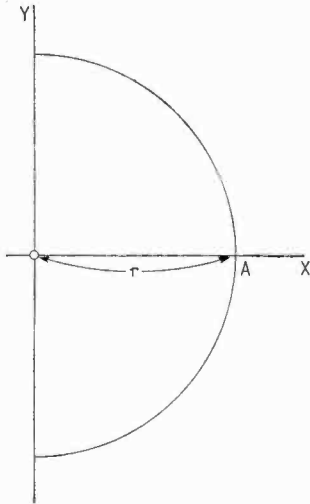
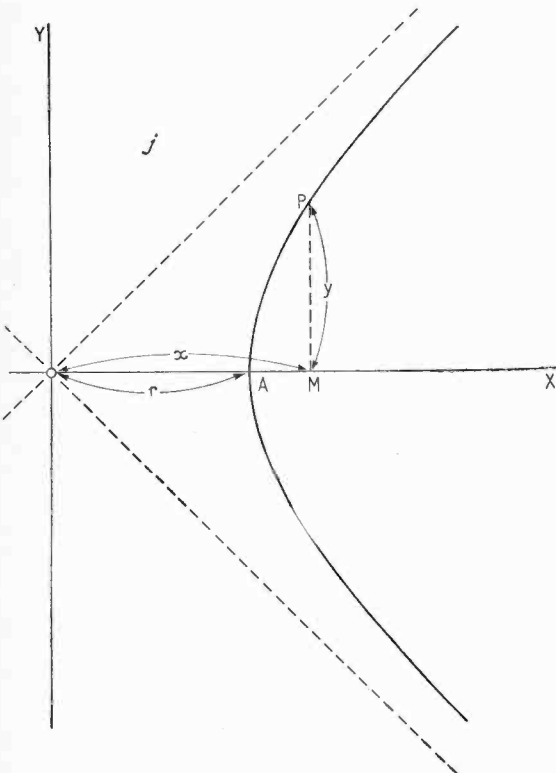

Fig. 3. Other measures of an angle are based on the trigonometrical ratios between  $x$ ,  $y$  and  $r$ .

Right: Fig. 4. Plotting a graph from the Pythagoras relationship for a triangle with one side ( $r$ ) of constant length gives this result for positive values of  $x$  not exceeding  $r$ . The other half of the circle comes from negative values.



Below: Fig. 5. When  $x$  exceeds  $r$ , that part of the graph is "imaginary," but with the aid of a  $j$  takes this form, with a mirror image symmetrically on the left.



to the angle, are the arc traced out by the tip of a radius while turning through the angle, and the radius itself; for example,  $AP/OA$  in Fig. 2. If the length of  $OA$  is always made equal to 1, then the length of  $AP$  is a logical measure of the angle, and in fact has been adopted as the "natural" angular measure, the unit ( $AP = 1$ ) being the radian. A protractor works on this principle, though it is usually scaled in degrees. If its radius were, say, 2 inches, then every 2 inches around the circumference would be 1 radian or  $360/2\pi$  degrees.

Another thing the angle is directly proportional to is the area swept out: the shaded sector in Fig. 2. The area swept out by  $2\pi$  radians, being a complete circle, is  $\pi r^2$ ; and if again we make  $r = 1$  we have the number of radians in any angle numerically equal to twice the area of the sector. We don't usually use that as a method of measuring angles, but it should be carefully noted for comparison later on.

Our typical angle appears yet again in Fig. 3, this time fitted into the conventional  $XY$  axes with its point coinciding with the "origin".  $PM$  is a vertical dropped from  $P$  to the  $X$  axis, and  $OM$ ,  $MP$ , are the co-ordinates  $x$  and  $y$  of the point  $P$ . The ratio  $x/r$  is called  $\cos \theta$ ,  $y/r$  is  $\sin \theta$ ,  $y/x$  is  $\tan \theta$ , and so on. It is clear enough why these are often called circular functions.

Bringing out another old friend—Pythagoras—we remember that  $x^2 + y^2 = r^2$ . This, in fact, is the equation of a circle of radius  $r$ , by which is meant that all possible positions of  $P$  plotted from it lie on such a circle. Familiar though this idea may be, join me in plotting it. For convenience we can bring  $x$  to the other side of the equation:  $y^2 = r^2 - x^2$ . We begin with  $x = 0$ , which reduces the equation to  $y^2 = r^2$ , from which we get  $y = r$  or  $-r$  (don't forget that quadratic equations have, in general, two solutions, because  $(-r)^2$  is the same as  $(+r)^2$ ). That gives two positions for  $P$ , both on the  $Y$  axis; and, incidentally, two values for  $\theta$ :  $\pm \pi/2$  radians. As we increase  $x$ ,  $P$  descends from its upper position, and ascends from its lower position, until at  $x = r$  they both merge into a single point on the  $X$  axis, completing a semicircle as in Fig. 4. (The other semicircle is, of course, obtained by values of  $x$  between 0 and  $-r$ .)

We have now reached a crisis—using that word literally, as a separating or turning point. Directly  $x$  exceeds  $r$ ,  $y^2$  becomes negative, so  $y$  is imaginary (in the mathematical sense). That means we can't find it on our graph as at present constituted, but we might be able to find it elsewhere. Remember, our equation is

$$y^2 = r^2 - x^2$$

which is the same as

$$y^2 = -1(x^2 - r^2).$$

$$\begin{aligned} \text{So } y &= \pm \sqrt{-1 \sqrt{x^2 - r^2}} \\ &= \pm j \sqrt{x^2 - r^2} \end{aligned}$$

In connection with a.c. theory and vectors we have (with some logical justification) interpreted  $j$  as a change of direction through one right angle. That had the effect of extending the scale of numbers reckoned in one dimension (i.e., parallel to the  $X$  axis) into the second dimension provided by the  $Y$  axis. In plotting our graph, however, we are already using these two dimensions, the understanding being that  $y$  is measured vertically, without the need for a  $j$

(Continued on page 235)

to give that instruction. Now that we are confronted by a  $j$ , how do we interpret it?

One way of plotting a curve from the equation  $y = \pm \sqrt{x^2 - r^2}$  in such a way as not to come into our present Fig. 4 is just to use a separate diagram marked with a  $j$  to distinguish it as belonging to a different world, only imaginary to the Fig. 4 beings. This is done in Fig. 5. Like Fig. 4, the complete graph includes a mirror image on the left-hand side of the Y axis, produced by negative values of  $x$ . Note, too, that to the Fig. 5 being the graph for values of  $x$  less than  $r$  (i.e., the Fig. 4 graph) is imaginary.

Another way of representing this mutual imaginarity is to draw Fig. 5 at right angles to Fig. 4 by folding the paper about the vertical line  $x = r$ , which of course includes the one point (or rather, including  $x = -r$ , pair of points) common to both graphs. The result, drawn in perspective, is something like Fig. 6. This, of course, is where I got my front and end view idea. And there is perhaps some justification for it, because the circle and the hyperbola (as the Fig. 5 curve is called) are both conic sections; that is to say, curves formed by the intersection of a cone and a plane. Fig. 5 is that particular kind of hyperbola called rectangular, because for values of  $x$  very much greater than  $r$  its extremities approach the dotted lines, which are at right angles to one another. In this special case the cone, split down the axis, must make a right angle at its apex. There is surely some significance in the fact that if such a cone were placed with its axis through the origin 0, at right angles to the Fig. 4 graph, slicing its top off would produce our circle and slicing its flanks off would produce our rectangular hyperbola. In other words, the natural positions of these two conic sections are at right angles to one another as shown in Fig. 6.

Be that as it may, there is no doubt that  $y^2 = r^2 - x^2$  gives us a circle when  $x$  is not larger than  $r$ , and a hyperbola in a  $j$  world when  $x$  is not smaller than  $r$ , for the simple reason that  $r^2 - x^2 = j^2(x^2 - r^2)$ ; while the equation  $y^2 = x^2 - r^2$  gives a hyperbola when  $x$  is not smaller than  $r$ , and a circle in a  $j$  world when  $x$  is not larger than  $r$ , for the simple reason that  $x^2 - r^2 = j^2(r^2 - x^2)$ . We can therefore reasonably look on these two equations as two different views of the same equation, the  $j$  denoting the difference in viewpoint. To the circle, the hyperbola is imaginary; to the hyperbola, the circle is imaginary. We, using our magic key  $j$ , can move from one to the other. We are likely to be prejudiced in favour of the circle, because we are used to it; but that is a merely human failing, unworthy of a mathematician. Having studied circular angles and functions, really all we need say is that hyperbolic angles and functions are essentially the same,  $x$  being greater than  $r$  instead of less, which means in the other world. Provided the N.S.P.C.C. didn't intervene one could bring up a child from infancy to think of  $x$  as normally not less than  $r$ , in which case the real form of the equation to him would be  $y^2 = x^2 - r^2$ , with its straightforward hyperbolic by-products, and the circle, with its angles and circular functions, would be round the corner in a  $j$  world, very difficult to understand.

As we are assumed to have been all brought up in the circular world, ignorant of the hyperbolic half of the picture, what we need to do now is review the same thing all over again on the assumption that  $x > r$  and see where it takes us. The main thing we

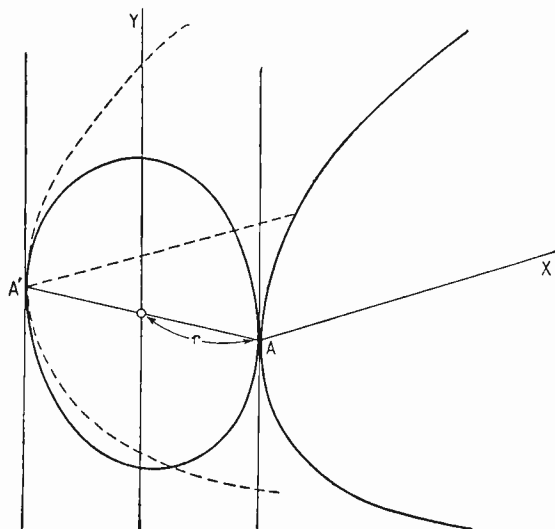

Fig. 6. If three dimensions are used, as here, the Fig. 4 and Fig. 5 parts of the graph can be shown in one diagram, which incidentally helps to show that they are both sections of the same cone.

have established so far is that we have to use the passkey  $j$  to transfer from our familiar world to the hyperbolic one or back again.

That being so, the most significant point on the diagram is not the origin 0, but the point A common to both worlds, distant  $r$  to the right (and left) of it. Here,  $y = 0$ . When  $x$  is made less than  $r$ ,  $y$  increases positively and negatively and the point P traces out our circle; when it is made greater, it traces out our hyperbola. In the first case P makes an increasing angle  $\theta$  with 0, proportional to the area swept out (in radians,  $\theta$  is numerically equal to  $2C/r^2$ , C being the area). In the second case it also makes an increasing angle with 0, limited however to a maximum of  $\pm 45^\circ$  or  $\pi/4$  radians. But now that we are in the hyperbolic world we must temporarily forget about the familiar circular angle of commerce, seen as the inclination of one line to another. The true measure of the hyperbolic "angle" is the area swept out by OP as it moves from the zero position OA. If this area, shaded in Fig. 7, is designated H, the hyperbolic "angle" is numerically equal to  $2H/r^2$ , in exact analogy with  $\theta$ . To denote this hyperbolic "angle" by  $\eta$  or by any of the other common symbols for circular angles, such as  $\phi$  or  $\psi$ , would encourage novices to fall into the trap of thinking of it in "circular" fashion as AOP. That is fatal. So I will use the rhyming symbol  $\eta$  (eta), to suggest that it is a twin of  $\theta$  (theta) but unlike to look at. We have, then

$$\eta = \frac{2H}{r^2}$$

The fact that the analogy between  $\eta$  and  $\theta$  is based on area, which is not a familiar way of reckoning the magnitude of  $\theta$ , and that there seems to be nowhere on the diagram to mark  $\eta$ , accounts for at least some of our reluctance to enter the hyperbolic world, especially as the area H is not nearly so easy as C to calculate or measure. However, we don't have to do that in order to use hyperbolic functions: the only reason for looking at it now is

to see where the connection lies between  $\eta$  and  $\theta$ . When  $H$  is calculated from the equation of the curve ( $y^2 = x^2 - r^2$ ), by means of an integration which anyone sufficiently interested can look up in a book, it turns out thus:

$$H = \frac{r^2}{2} \log_e \frac{x+y}{r}$$

So, substituting for  $H$  in our formula for  $\eta$ ,

$$\eta = \log_e \frac{x+y}{r}$$

which is the same thing as

$$e^\eta = \frac{x+y}{r}$$

It may not be obvious where this is leading, but have patience. By dint of a little manipulation\* this  $(x+y)/r$  is found to be the same thing as  $r/(x-y)$ , so  $1/e^\eta = e^{-\eta} = (x-y)/r$

Hold those apparently useless pieces of information for a minute while we rejoin the more obvious trail by defining the hyperbolic functions. They are exactly the same ratios as the circular functions, but to show that they relate to hyperbolic "angles" their names incorporate the distinctive "h":

$$\cosh \eta = \frac{x}{r}$$

$$\sinh \eta = \frac{y}{r}$$

$$\tanh \eta = \frac{y}{x}$$

and correspondingly for  $\operatorname{sech}$ ,  $\operatorname{cosech}$  and  $\operatorname{cotanh}$ . In case the uninitiated are getting out of breath trying to say "sinh" and "tanh," I should explain that they are pronounced "shine" and "than" (th as in thank), and "sech" is "sheck."

Nothing could be simpler and more familiar than these ratios: the snag is that  $\eta$  is so hard to visualize compared with  $\theta$ . This is where we can reap the fruit of our work on  $H$ . With perhaps a recollection of last month's study of  $e$  to guide us, we take the average of the values we have just found for  $e^\eta$  and  $e^{-\eta}$ , thus:

$$\begin{aligned} \frac{e^\eta + e^{-\eta}}{2} &= \left( \frac{x+y}{r} + \frac{x-y}{r} \right) / 2 \\ &= \frac{x}{r} = \cosh \eta \end{aligned}$$

Compare this with what we found last month about  $\cos \theta$ :

$$\cos \theta = \frac{e^{j\theta} + e^{-j\theta}}{2}$$

The same except for the  $j$ ! And we have already seen that moving from the hyperbolic world with its  $\cosh \eta$  to the circular world with its  $\cos \theta$  we must use  $j$  as the key. Whereupon you may remind me that I said the same key is needed for the reverse journey, so what about when  $j$  is already present, as in the formula for  $\cos \theta$ ? Well, I'm fully covered there, because it is all the same whether you remove those  $j$ s, or square them. Try it and see! Since

$$\frac{x+y}{r} = \frac{\sqrt{(x+y)^2}}{\sqrt{x^2-y^2}} = \frac{\sqrt{(x+y)(x+y)(x-y)}}{\sqrt{(x+y)(x-y)(x-y)}} = \frac{\sqrt{x^2-y^2}}{\sqrt{(x-y)^2}} = \frac{r}{x-y}$$

$j^2 = -1$ , the two  $e$  terms simply change places.

By now you will know what to expect from subtracting  $e^{-\eta}$  from  $e^\eta$  and dividing by 2:

$$\frac{e^\eta - e^{-\eta}}{2} = \sinh \eta$$

The corresponding formula for  $\sin \theta$  is  $(e^{j\theta} - e^{-j\theta})/2j$ ; there is a  $j$  in the denominator as well. This, as we saw last month, is necessitated by the fact that  $y$  is at right angles to  $x$ . The youth who had been brought up in the hyperbolic world would of course point to these  $j$ s in the exponential formulae for  $\sin$  and  $\cos$  as examples of how mysterious and unnatural that circular world must be and how difficult to learn.

And, certainly, now that we are here in the hyperbolic world it doesn't look so bad as it did from the circular viewpoint. It is easy enough to plot curves of  $e^\eta$  and  $e^{-\eta}$  and from them derive curves of  $\cosh \eta$  and  $\sinh \eta$  without having to turn our brains inside out trying to visualize the effect of imaginary indices. In Fig. 8 look first at the exponential or compound-interest curve,  $e^\eta$ , which we studied in such detail last month. Having refreshed our memories with that, look next at the  $e^{-\eta}$  curve; since the only difference is the minus, it is just a left-to-right mirror image of the first curve. If now a curve is drawn vertically midway between these two it represents their average, which, as we have just seen, is  $\cosh \eta$ . If it looks like a hanging chain, that is hardly surprising, because a chain hangs in a  $\cosh$  curve. Its symmetry means that  $\cosh(-\eta) = \cosh \eta$ . The farther from the centre,

Fig. 7. Just as circular angles are proportional to area swept out (Fig. 2), so are hyperbolic "angles." And the hyperbolic functions are the same ratios as the circular ones.

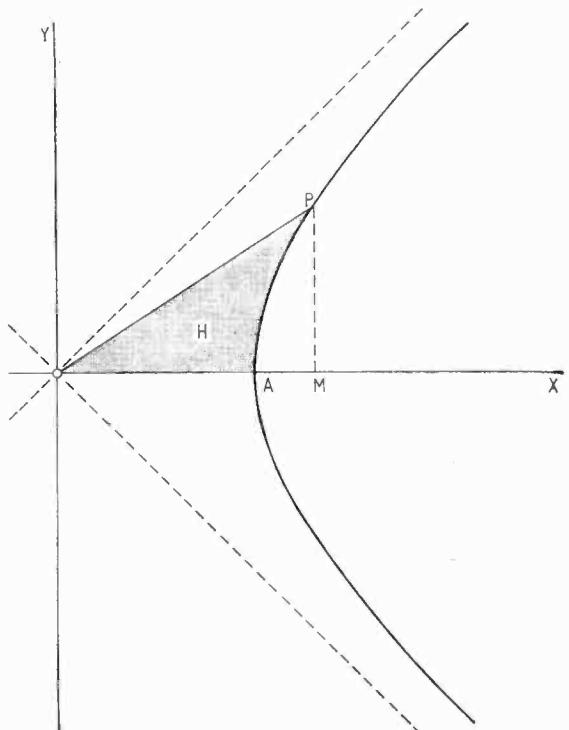
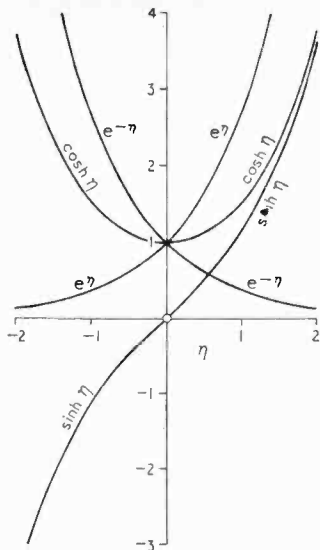

Fig. 8. Cosh  $\eta$  and sinh  $\eta$  are respectively half the sum and difference of  $e^\eta$  and  $e^{-\eta}$  ( $=1/e^\eta$ ), so their curves can easily be plotted from last month's exponential curves.



the less significant is the lower exponential contribution and the closer cosh  $\eta$  approaches  $\frac{1}{2}e^\eta$  on the positive side and  $\frac{1}{2}e^{-\eta}$  on the negative side. The same is true of the sinh  $\eta$  curve, but because  $\frac{1}{2}e^{-\eta}$  is subtracted from  $\frac{1}{2}e^\eta$  to get it, the curve is skew symmetrical; that is to say, the negative half is the same as the positive half swung  $180^\circ$  about 0. In other words,  $\sinh(-\eta) = -\sinh \eta$ .

Like the circular functions, the hyperbolic functions can be calculated to any desired number of decimal places by adding an appropriate number of terms in the equivalent series. And as we now have them in terms of  $e^\eta$ , and we found the series for  $e^x$  last month, there is no need for me to do more than put down the results for comparison with those for cos and sin:

$$\cosh \eta = 1 + \frac{\eta^2}{2!} + \frac{\eta^4}{4!} + \dots$$

$$\sinh \eta = \eta + \frac{\eta^3}{3!} + \frac{\eta^5}{5!} + \dots$$

The cos and sin series, you may remember, were the same except for every even term being negative.

The hyperbolic analogue of the famous Euler identity is (as we would now expect) the same without  $j$ :

$$e^\eta = \cosh \eta + \sinh \eta$$

Fig. 8 shows the truth of this very clearly.

And so we could amuse ourselves for quite a long time, deriving the hyperbolic formulae corresponding to the long list of circular ones. For instance, the well-known  $\cos^2 \theta + \sin^2 \theta = 1$  is matched by  $\cosh^2 \eta - \sinh^2 \eta = 1$ . Even more basic are the direct transfers from one to another, using our passkey:

$$\begin{aligned} \cos A &= \cosh jA & \cosh A &= \cos jA \\ j \sin A &= \sinh jA & j \sinh A &= \sin jA \end{aligned}$$

I have used A here because it is a neutral symbol having no exclusive associations with either world. The books usually use  $x$ , which is also delightfully neutral, but we have been using  $x$  in Figs. 3-7 for something quite different, and I'm anxious not to confuse the two things.

By the time we'd worked through the whole lot,

with only the odd  $j$  and occasionally a minus sign to distinguish formulae in one world from those in the other, we would surely be convinced that there is a close connection between the two worlds, in spite of hyperbolic angles seeming to be so much less satisfactory than circular angles. You may also be contrasting the cosh and sinh curves in Fig. 8 with the cos and sin waves we know so well. True, both lots have the same kinds of symmetry, but there seems to be nothing about the hyperbolic curves to match the periodicity—the endless repetition—of the sin and cos waves. Yet there is, you know!

The period, or wavelength, of  $\sin \theta$  is of course  $2\pi$ —one whole revolution or cycle. At the end of that it is back where it started—at zero, ready to increase positively. Any whole number of times  $2\pi$  added to  $\theta$  makes no difference. Moving into the hyperbolic world we have to use our key, so we are not surprised to find ourselves with  $j2\pi$  to examine. By all logic, this ought to be the period of our hyperbolic "angle,"  $\eta$ . And if we put  $\eta = j2\pi$  in any of our formulae for cosh  $\eta$ , we find it comes out as  $\cos 2\pi$ , which of course is the same as  $\cos 0$ , viz., 1. The same goes for any whole-number multiple of  $j2\pi$ . So cosh  $\eta$  has the imaginary periodicity  $j2\pi$ , analogous to the  $2\pi$  periodicity of  $\cos \theta$ . Similarly for the other hyperbolic functions. I can't really claim to be able to visualize this periodicity clearly, but it is consistent with the way that  $j$  seems to swing us through a right angle from the hyperbolic plane in Fig. 6 into the circular, or the other way about.

Still less have I a clear picture of hyperbolic functions of complex "angles"; that is to say, values of  $\eta$  which are a mixture of "real" and "imaginary" quantities. Unfortunately it is precisely these that are most useful. Fortunately it is quite easy to derive mixed circular and hyperbolic formulae involving only the real or only the imaginary part in any one factor. But we had better not get too deeply involved with them until we have room to include some practical applications.

## Club News

**Cleckheaton.**—Dr. J. Sikorsky will give a lecture on the electron microscope to members of the Spen Valley Amateur Radio Society at Leeds University on May 11th. The Northern Mobile Rally will be held at Harewood House, West Leeds, on May 22nd.

**Leeds.**—The month's programme of the Leeds Amateur Radio Society (G3BEW) includes a film show in the Department of Psychology at the University on the 4th, and a lecture-demonstration on tape recorders on the 11th at Swarthmore Education Centre, 4 Woodhouse Square.

**Ramsgate** is the venue of the mobile rally organized by the Thanet Radio Society (G3DOE) for May 8th. Weekly meetings are held on Fridays at 8.0 at Hilderstone House, St. Peter's, Broadstairs.

**Reading.**—L. Williams, of the Belclere Co., will give a lecture on sub-miniature techniques at the meeting of the Calcot Radio Society on May 19th. Meetings are held at 7.45 in the St. Birinus Church Hall, Langley Hill, Calcot.

**Southend.**—The Pocock Cup, presented many years ago by our managing editor, who was then editor, has been awarded by the Southend and District Radio Society to J. K. Whybrow for his home-constructed 80/160-metre transmitter with built-in power pack and v.f.o. A. C. Wadsworth, who also exhibited a top-band transmitter, was awarded the Hudson Cup.

**Worcester.**—The inaugural meeting of the Worcester and District Amateur Radio Club, was held on February 27th. The Club has the exclusive use of a room at the Y.M.C.A. Building, Henwick Road, where it is planned to install a transmitter. Secretary: R. D. Pritchard (G3NXE), 42a Avon Road, Tolladine, Worcester.

## Further Thoughts on

# Stereophonic Sound Systems

By D. M. LEAKEY,\* Ph.D. (Eng.), B.Sc. (Eng.), D.I.C., A.C.G.I., Grad. I.E.E.

## 2. PRACTICAL SYSTEMS COMPARED

(Concluded from p. 160 of the April issue)

**M**OST stereophonic sound systems at present in use consist essentially of two or more spatially separated loudspeakers fed through separate channels from separate, suitably positioned microphones. In detail, however, considerable differences exist. Considering only two-channel systems, the basic microphone techniques in common use are:

(a) Spaced omnidirectional microphone technique.

(i) The wide-spaced technique (5-20 ft)<sup>12, 13</sup>.

(ii) The close-spaced technique<sup>11, 14</sup>.

(b) The technique employing omnidirectional microphones mounted in an artificial head or on either side of a shadow board<sup>11, 14</sup>.

(c) The close-spaced (ideally zero) directional microphone technique<sup>1, 15</sup>.

These methods are illustrated in Fig. 19. Hybrid

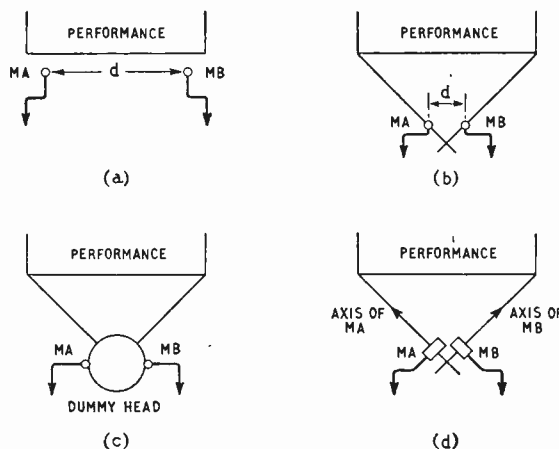

Fig. 19. Microphone arrangements. (a) Widely spaced omnidirectional microphones. (b) Closely spaced omnidirectional microphones. (c) Omnidirectional microphones mounted in an artificial head. (d) Closely spaced directional microphones.

methods also exist, both to obtain special effects, and to attempt to correct for the limitations of the more basic systems, as described above.

Before attempting to compare the relative merits of these systems, it is first necessary to decide what is to be the aim of a stereophonic sound system. Within the present limited capacity of the systems, it appears best to consider the requirements as suggested originally<sup>1</sup>. In Fig. 20, which is virtually a reproduction of Fig. 5 in the original article<sup>1</sup>, the aim is considered achieved if the spaced, independ-

ent sound sources are perceived by the listener as spaced independent sound images, arranged to line up spatially with the original sound sources. This agreement is required only within some definite and limited pickup angle.

Considering first the wide-spaced omnidirectional microphone technique, a typical arrangement is illustrated in Fig. 21, together with the effective resultant interchannel time and intensity differences for sound sources in the positions S0-S8. It is assumed that the listener at the loudspeaker terminal is centrally located. From the tabulated figures it can be seen that this method results in the production of interchannel time differences of relatively large magnitude. Unfortunately, the resultant sound image positions are likely to be badly defined as the effects of interchannel time difference tend to be very variable. Further, the time differences produced in this example are large. In many cases the interchannel time difference is sufficient to locate all the stereo sound images well over to the extremes of the actual loudspeaker positions, except that sound image associated with the central sound source. The foregoing remark is only true when the sound sources are radiating sounds with a relatively complex wave form. When tone signals are being radiated, or when noise and reverberation levels are high, all the sound images would tend to be bunched together in the centre. Since most sounds are normally complex, the effect of bunching at the extreme loudspeaker positions is normally noticed. The "hole in the middle," which thereby results, is often "cured" by introducing a completely independent third channel, or by deriving a sum signal of some sort from the left and right channels, which is fed to a central loudspeaker. The first method gives a worth-while improvement, but it is doubtful if the second method does little more than could be achieved by moving the left and right loudspeakers inwards. However, claims have been made for improvements resulting from the use of special electrical networks to feed the central loudspeaker.

To avoid trouble, due to lack of sound spread between the loudspeakers, it is quite common with spaced microphone techniques to employ up to about six channels. The lack of spread is then of little consequence, the system being essentially a six-source system. As a sound image tends to be locked hard to a particular loudspeaker, the system has the advantage that nothing terrible happens when the listener moves off-centre. This is of obvious importance for large audience work, but six channel systems are rather too expensive for home use.

Another fault is sometimes observed when widely

\*Research Laboratories of the General Electric Company Limited, Wembley, England.



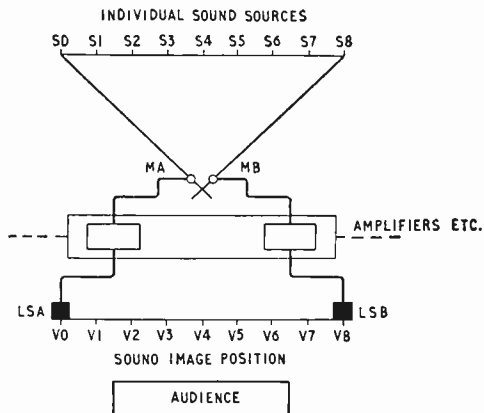

Fig. 20. Simplified requirement of a two-channel system.

spaced microphones are used. Due to the large interchannel time delays produced, "splitting" of a sound image sometimes occurs, and a particular sound source appears to be emanating from both loudspeakers separately. Although really a fault, this echo effect often sounds quite pleasing.

Some of the above faults can be reduced by decreasing the microphone spacing so that, for a given sound source displacement, smaller time differences are produced. The variability of the effect of interchannel time difference, however, still remains.

In the dummy head method, the two microphones are mounted in either side of a solid sphere. The method appears to have originated as a result of the apparently mistaken idea that the left loudspeaker excites only the left ear of the listener and the right-hand speaker only the right ear.

The effect of a dummy head, interposed between the microphones, is to increase the interchannel intensity differences produced, mainly at high frequencies. The interchannel time difference, for a given sound source displacement, is also slightly increased.

By suitable choice of dummy head, it appears possible to obtain reasonable results using this method<sup>11</sup>. It is, however, difficult to see how it can offer much improvement over a spaced microphone technique except that annoying cancellations, which occur when the microphone spacing becomes comparable with a half wavelength, are reduced.

It was shown previously that a stereo sound image, as perceived by a centrally located listener, could be displaced reliably by introducing an interchannel intensity difference. Such an interchannel intensity difference can be produced by directional microphones, suitably orientated and ideally with zero separation<sup>1,15</sup>. Fig. 22 shows a typical arrangement with two pressure gradient microphones (such as ribbon microphones) mounted with their axes at 90 degrees. The table lists the effective interchannel intensity differences produced by the sources. These figures are compared with:

- (a) The practical results
- (b) Equation (8).
- (c) Equation (9).

Note that the resultant interchannel intensity difference is exactly the same as that dictated by eqn. (9), and very nearly the same as that suggested by the

practical results. The agreement with eqn. (9) follows from simple trigonometrical considerations.

For the higher frequencies suitable electrical cross coupling between the channels could be employed to allow for the modified requirements.

Microphones, other than the ribbon type, can be used providing the directional characteristics are maintained throughout the reproduced frequency range. Directional characteristics at high frequencies only would appear to be insufficient. The practical and theoretical results indicate that the phasing of the loudspeakers is important at low frequencies but relatively unimportant with average loudspeakers at high frequencies.

It should be noted that the setup shown in Fig. 22 is only correct for the major 90-degree pick-up angle. For the remaining 270 degrees the stereo reproduction is incorrect. Possibly some improvement in the overall effect could be achieved by spacing the microphones a small amount, although this could degrade the apparent sound quality due to cancellation effects, which might be introduced thereby. These effects might be reduced by including some sort of mask between the microphones.

The above comments apply to the case with a listener seated on-centre. Unfortunately, with an audience consisting of many people, only a few of the listeners can occupy central positions. As has been mentioned, off-centre listening introduces a

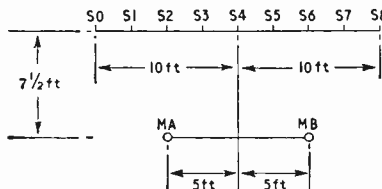

SOUND SOURCE POSITION	EFFECTIVE INTERCHANNEL TIME DIFFERENCE (msec)	EFFECTIVE INTERCHANNEL INTENSITY DIFFERENCE (dB)
S4	0	0
S3 OR S5	2.5	2.7
S2 OR S6	4.5	4.5
S1 OR S7	6.2	5.4
S0 OR S8	7.1	5.4

Fig. 21. Typical spaced microphone arrangement.

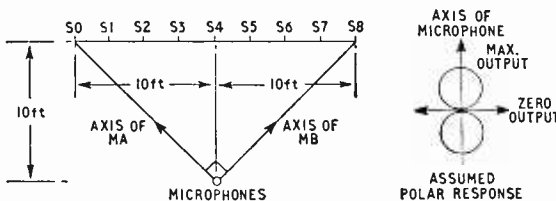

SOUND SOURCE POSITION	EFFECTIVE INTERCHANNEL INTENSITY DIFFERENCE (dB)	REQUIRED INTERCHANNEL INTENSITY DIFFERENCE (dB)		
		FROM FIG.7	FROM EQN.8 (FOR b=8ft)	FROM EQN.9
S4	0	—	0	0
S3 OR S5	4.5	4.5	5.2	4.5
S2 OR S6	9.5	10.1	11.1	9.5
S1 OR S7	16.9	17.1	19.2	16.9
S0 OR S8	∞	—	∞	∞

Fig. 22. Typical directional microphone arrangement.

serious interchannel time difference and a less important interchannel intensity difference. Whereas the interchannel intensity difference can be compensated for almost exactly by the use of directional loudspeakers, it is very much more difficult to allow for the interchannel time difference. Loudspeakers with time difference polar diagrams have been suggested but have practical limitations. Compensating interchannel time differences with interchannel intensity differences by increasing the directional characteristics of the loudspeakers, might be more satisfactory if an exact equivalence existed. However, some compensation, over that required for interchannel intensity difference alone, seems desirable, although difficult to achieve throughout the audio range.

Unfortunately, it appears that interchannel time difference, produced either unavoidably or intentionally, will always provide a serious problem with stereo systems as at present envisaged.

All the above remarks apply to systems in which an attempt is made to obtain a correct spacing of the stereo sound images. Most systems, however, do not aim to do this. They aim only to produce a spread of the sound images which seems pleasant. Often it is the case that the more "ethereal" the sound images appear, then the better the system is appreciated. Such systems can be regarded, however, only as attempts at pseudo-stereophony, even though two channels might be employed.

Finally a mention must be made about headphone listening, which is supposed by some to be ideal. It might be almost ideal provided the recording microphones could be made to move in accordance with the listener's head. Without such a linkage the sounds usually appear to emanate from just behind the head, which would be considered by most to be very unnatural. It is also very important to note that with headphone listening, the "crossed" signals are effectively absent. The left and right signals required for headphone listening are completely different therefore from the signals required to feed the loudspeakers for normal stereo listening.

**Conclusion.**—A few months ago in this journal an article was entitled "The Great Stereophony Fake."<sup>16</sup> Was this title justified? It appears to

depend on what is wanted. If a system is required in which exact positional information is to be transmitted, then it is unlikely that any present-day system is anywhere near perfect, although the directional microphone techniques come a long way to achieving the desired result. If, however, only an improvement over single channel reproduction is required, but exact location is not aimed at, then most systems provide some enhancement of the sense of spaciousness.

**Acknowledgments.**—Acknowledgments are due to Professor E. C. Cherry and to Mr. F. H. Brittain for help and encouragement while the original work was being undertaken. The author is very grateful also to the patient subjects, who spent many restful hours being "tested."

[*Corrections.* In the first part of this article (April issue) p. 157, equation (9) should have an "approximately equals" sign after  $\tan \alpha$ ; and on p. 158, right-hand column, line 2, the "source at an angle  $\alpha$  gives the final result".]

## REFERENCES

- 1 Brittain, F. H. and Leakey, D. M., 1956, *Wireless World*, Vol. 62, No. 5 (May 1956).
- 2 Brittain, F. H. and Leakey, D. M., 1956, *Wireless World*, Vol. 62, No. 7 (July 1956).
- 3 Leakey, D. M. and Cherry, E. C., *J.A.S.A.* Vol. 29, p. 284 (1957).
- 4 Leakey, D. M., *J.A.S.A.*, Vol. 29, p. 966 (1957).
- 5 Leakey, D. M., Sayers, B.McA., and Cherry, E. C., *J.A.S.A.*, Vol. 30, p. 222 (1958).
- 6 Leakey, D. M., *J.A.S.A.*, Vol. 31, p. 977 (1959).
- 7 Leakey, D. M., B.S.R.A. Stereo Symposium Oct. 1959.
- 8 Licklider, J. C. R. and Webster, J. C., *J.A.S.A.*, Vol. 22, p. 191 (1950).
- 9 Haas, H., *Acustica*, Vol. 1, p. 49 (1951).
- 10 Parkin, P. H. and Scholes, W. E., *Wireless World*, Vol. 57, No. 2 (Feb. 1951).
- 11 de Boer, K., *Philips Technical Review*, Vol. 5 (1940).
- 12 Steinberg, J. C. and Snow, W. B., *B.S.T.J.*, Vol. 13 (1934).
- 13 Snow, W. B., *J.S.M.P.T.E.*, Vol. 61 (1953).
- 14 de Boer, K., *Philips Technical Review*, Vol. 8 (1946).
- 15 Clark, H. A. M., Dutton, G. F. and Vanderlyn, P. B., *J.I.E.E.*, Vol. 104, Part B (1957).
- 16 "Cathode Ray," *Wireless World*, Vol. 65, No. 8 (Sept. 1959).

## Commercial Literature

**T.W.T. Communications System** for the 4000Mc/s band, with wide-band response suitable for 600 or more telephone channels or a monochrome or colour television channel. Transmitter output power is 4 watts, the 10ft diameter paraboloid aerials have a gain of 39dB and the range for each hop is up to 35 miles. Illustrated brochure from Marconi's Wireless Telegraph Company, Marconi House, Chelmsford, Essex.

**High Density Material**, called Mallory 1000, suitable for balancing and counterbalancing in instruments and for radiation shielding. Made by powder metallurgy from tungsten, nickel and copper, it has uniform structure, specific gravity 50% greater than lead, and can be machined by normal methods. Physical properties in a data sheet from Johnson Matthey & Co., 73-83 Hatton Garden, London, E.C.1.

**Miniature Paper Capacitors**, tropical low-voltage types (150V working), measuring  $\frac{1}{16}$ in long by  $\frac{1}{16}$ in diameter according to value (0.01 $\mu$ F to 0.25 $\mu$ F). Technical Bulletin No. 67 on the "Metalmite" range from The Telegraph Condenser Co. (Radio Division), North Acton, London, W.3.

**Analogue Computer Tutor**, a simple analogue computer for training purposes, containing five drift-corrected opera-

tional amplifiers, eight coefficient potentiometers, a control and patching panel and the necessary power supplies. Leaflet from The Solartron Electronic Group, Thames Ditton, Surrey.

**V.H.F. Communications Receiver**, 13-valve double superhet, for reception of a.m. or c.w. transmissions in the 2-metre amateur band. Frequency range is 143-147Mc/s and sensitivity 1 $\mu$ V for 50mW output. A crystal calibrator is an optional extra. Leaflet from R.E.E. Telecommunications, Ltd., Telecomms Works, Market Square, Crewkerne, Somerset.

**Double-Reflection Galvanometer**, giving double the normal sensitivity, is a new addition to the well-known "Scalamp" range of instruments. This and other new developments appear in the latest illustrated Catalogue "N" from W. G. Pye & Co., Ltd., Granta Works, Cambridge.

**P.V.C. Plastics.**—A simple guide to their chemical nature, forms and applications in a well-illustrated booklet "The Geon Story" containing many photographs of typical uses. From British Geon, Ltd., Devonshire House, Piccadilly, London, W.1.

**Stabilized D.C. Power Unit**, 0-72V, 0-1.5A, with stability of  $\pm 50$ mV and full-load ripple of  $< 0.02\%$ , is one of the newer instruments listed in the 1959 abbreviated catalogue from Servomex Controls, Ltd., Crowborough, Sussex.

# LETTERS TO THE EDITOR

The Editor does not necessarily endorse the opinions expressed by his correspondents

## A Property of Negative Resistance

I HAVE read with interest the various articles on negative resistance by "Cathode Ray" and others which have appeared in the *Wireless World* at intervals over the past years.

I have particularly appreciated the thoroughness with which the true nature of negative resistance as it appears in practice has been exposed, and so it is with some diffidence that I describe a property of—for want of a better term—idealized negative resistance.

I define here a purely fictitious element  $(-R)$  ohms which is constant, independent of frequency, and which reacts to the flow of current through it in a manner exactly the opposite of that exhibited by a normal resistance, namely the exit point is positive with respect to the point of entry by an amount  $Ri$  volts, where  $i$  is the current flowing, in amperes.

It is not perhaps always realized that a tuned circuit may be over-damped by such a negative resistance just as easily as by a normal positive resistance.

Consider first the series-tuned circuit in which is included an element  $(-R)$  as defined above\*:

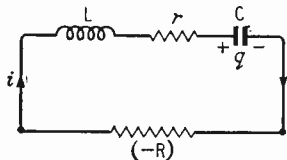

The equation for the total change of potential round the circuit is

$$L \frac{di}{dt} + ri + \frac{q}{C} - Ri = 0$$

Remembering that the current flowing is the rate of change of charge on the capacitor, we may differentiate the equation and obtain

$$LC \frac{d^2i}{dt^2} + C(r-R) \frac{di}{dt} + i = 0$$

This is a second-order linear differential equation of the form

$$T^2 \frac{d^2i}{dt^2} + 2aT \frac{di}{dt} + i = 0$$

\*If my definition of  $(-R)$  is regarded as unduly stringent, only a very minor change occurs in the equation for the parallel-tuned circuit case—not in any way affecting the conclusions—if you substitute the definition

$$(-R) = \frac{d^2v}{di}$$

in the place of

$$(-R) = \frac{vR}{i}$$

The possibility of assigning a negative a.c. resistance to part of a  $v/i$  characteristic is now admitted.—G. de V.

(This latter equation, by the way, describes the transient behaviour of a large number of both electrical and mechanical systems, a familiar one being the motion of the needle of a meter).

In this case,

$$T = \sqrt{LC} \text{ seconds,}$$

$$\text{and } 2aT = C(r-R) \text{ seconds,}$$

$$\text{making } a = \frac{1}{2}(r-R) \sqrt{\frac{C}{L}} = \frac{1}{2Q} \left(1 - \frac{R}{r}\right),$$

where  $Q = (L/C)^{1/2}/r$  is the "Q" of the tuned-circuit  $L, C, r$ , on its own.

We observe that, while  $T$  is essentially positive,  $a$  may be positive or negative according as  $R$  is less or greater than  $r$ .

The form of the solution of the above equation intimately depends on the roots of a subsidiary equation

$$T^2x^2 + 2aTx + 1 = 0,$$

namely

$$(-a + \sqrt{a^2 - 1})/T \text{ and } (-a - \sqrt{a^2 - 1})/T.$$

Briefly, assuming some current flowing in the circuit at  $t = 0$ , if  $1 < a < \infty$ , the current dies away to zero without oscillation, i.e. the current remains unidirectional.

This is the familiar "dead-beat" case, and the circuit is said to be over-damped.

For  $0 < a < 1$ , the term  $\sqrt{a^2 - 1}$ —a part of each root of the subsidiary equation—becomes imaginary, implying that the current oscillates with frequency  $\sqrt{1 - a^2}/2\pi T$  cycles per second. The amplitude of the oscillations dies away exponentially, with time-constant  $(T/a)$  seconds.

For  $-1 < a < 0$ ,  $\sqrt{a^2 - 1}$  is still imaginary and the current is therefore oscillatory, but the amplitude of the oscillations grows exponentially, with time constant  $(-T/a)$  seconds.

However, for  $-\infty < a \leq -1$ , i.e. when the negative resistance is as negative as, or more negative than,  $\{-r(1 + 2Q)\}$ , the term  $\sqrt{a^2 - 1}$  becomes real again, implying that the current is not oscillatory, but grows unidirectionally.

We can summarize these conclusions in the following diagram.

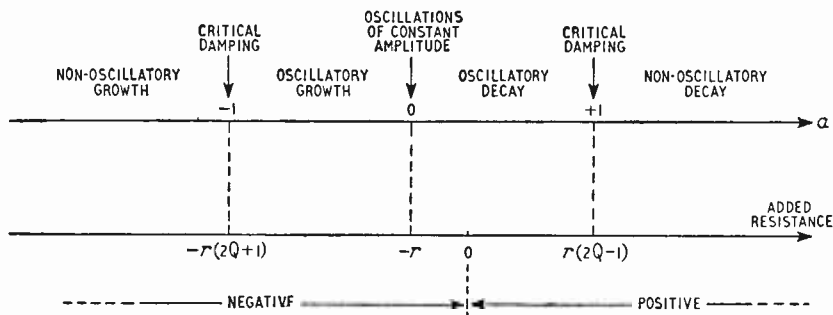

If we take a practical case, for instance a tuned circuit having a Q of 50 and resonating at 1 Mc/s when the capacitance is 150 pF, the resistance required for dead-beat growth of current has to be more negative than (-2000) ohms.

I hasten to add that if a resistance of the order of 2000 ohms were included in series with a series-tuned circuit, the net result would hardly warrant the title "tuned circuit", but the theoretical fact remains that in the case given, current would grow without oscillation; one is tempted to wonder what would happen in practice, where the range over which the negative-resistance device behaves like a negative resistance is strictly limited.

The case of a negative resistance across a parallel-tuned circuit is a little more interesting.

Here is the circuit

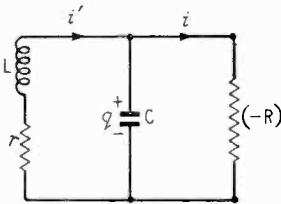

The equations for the potential difference round each mesh are

$$ri' + L \frac{di'}{dt} + \frac{q}{C} = 0 \dots\dots\dots (i)$$

and  $Ri + \frac{q}{C} = 0 \dots\dots\dots (ii)$

Also  $\frac{dq}{dt} = i' - i,$

So  $i' = i + \frac{dq}{dt} = i - CR \frac{di}{dt},$  from (ii)

From (i) and (ii) therefore, we have

$$r \left( i - CR \frac{di}{dt} \right) + L \left( \frac{di}{dt} - CR \frac{d^2i}{dt^2} \right) - Ri = 0$$

$$\text{i.e. } \left\{ \frac{LCR}{R-r} \right\} \frac{d^2i}{dt^2} + \left\{ \frac{CRr-L}{R-r} \right\} \frac{di}{dt} + i = 0,$$

which is once again a second-order differential equation of the same form as before, only this time

$$T = \sqrt{\frac{LCR}{R-r}} = \frac{\sqrt{LC}}{\sqrt{1-\frac{r}{R}}}$$

$$\text{and } a = \frac{1}{2} \frac{CRr-L}{\sqrt{LCR(R-r)}} = \frac{1}{2Q} \left( \frac{1-\frac{Z_d}{R}}{\sqrt{1-\frac{r}{R}}} \right)$$

where once again Q is  $(L/C)^{1/2}/r,$  and  $Z_d$  is the dynamic resistance  $L/Cr$  of the parallel-tuned circuit on its own.

Assuming a current in the circuit at  $t = 0,$  we can therefore expect  $i$  to vary in just the same way as before for corresponding values of  $a$  and  $T.$

We notice immediately that the numerator of  $a$  is positive or negative according as  $R$  is greater or less than  $Z_d.$

The case is slightly complicated by the fact that  $T$  and  $a$

are not necessarily real; if  $R$  is less than  $r,$   $T$  becomes imaginary, as also does  $a.$  However, looking back to the roots of the subsidiary equation, the portion  $(-a/T)$  thereof remains real for  $R$  less than  $r,$  whilst the portion  $\pm \sqrt{a^2 - 1}/T,$  real for  $R$  just greater than  $r,$  remains real as  $R$  falls below  $r,$  so in fact we need not consider the case of  $R$  less than  $r$  separately.

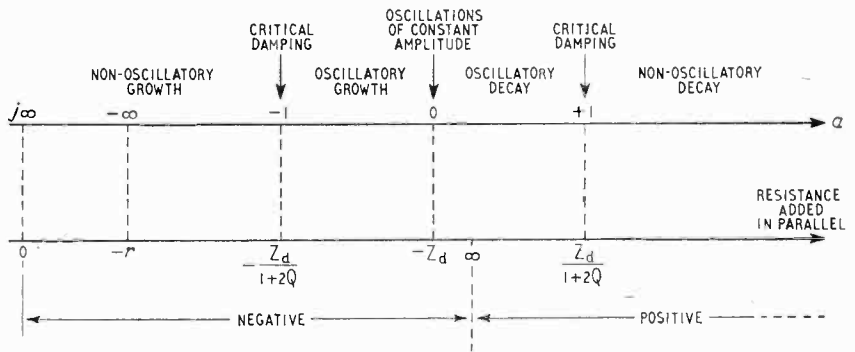

Thus, as for the case of the series-tuned circuit, we can summarize the behaviour in the diagram above.

Considering the same practical case as before, where the tuned circuit on its own has a Q of 50 and resonates at 1 Mc/s when the capacitance is 150 pF, non-oscillatory growth of current results from the addition in parallel of a negative resistance of value between zero and (-500) ohms.

Saffron Walden.

G. de VISME.

I MUST agree with "Cathode Ray" in his reply to my letter in the April issue that my third paragraph is not clear, in fact my typewriter seems to have left out a line at the end. This should have read " $-jX = j\omega(-L),$  or similarly when  $Z = R - jX,$  and  $-Z = -R - (-jX),$   $-(-jX) = -j/\omega(-C).$  I apologise to all concerned.

I think, however, a better way of explaining negative impedance is as follows.

In the Argand impedance diagram  $R \pm jX$  represents any positive impedance,  $-a$  resistance in series with a reactance. Obviously the sign of the reactance does not affect the sign of the impedance which must therefore be determined by  $R$  only.

A negative impedance is therefore represented by  $-R \pm jX.$

The question is what does  $\pm jX$  stand for?  $+jX$  can represent the reactance of a positive inductance  $j\omega L$  or the reactance of a negative capacitance,  $-j/\omega(-C) = j/\omega C.$  Similarly  $-jX = -j/\omega C$  or  $j\omega(-L) = -j\omega L.$

When we talk about a positive impedance we ignore the case of the negative component partly because it would require electronic means to produce it, and partly because the combination would not behave as an impedance, since it would be unstable.

When an e.m.f. is applied to a resistance in series with an inductance, at first the voltage appears wholly across the inductance, and the current increase at a certain rate in a certain direction. The resulting voltage built up across the resistance opposes the applied e.m.f., and reduces the voltage across the inductance. The current therefore increases more slowly and eventually becomes constant. With a resistance-capacitance combination the voltage builds up across the capacitance.

If the inductance is negative, the current flows in the opposite direction, but if the resistance is also negative the voltage across the resistance has the same polarity as before, and opposes the applied e.m.f. The same thing happens with negative capacitance.

But in any similar combination with one positive and one negative component the voltage built up aids the applied e.m.f., and the current increases indefinitely. The negative time constant identifies this class.

It might be wondered how this could happen with a positive impedance. We are so used to considering in a.c. circuits that the reactances are practically loss-free, that we forget that when a current is passed through an inductance initially dead it absorbs energy. The opposite happens with a negative inductance, and it supplies the extra energy required.

Similarly with a negative capacitance, with an applied initial e.m.f. however small and a positive resistance, it is self-charging, a negative resistance is required to discharge it.

Hence with negative impedance we ignore the case with the positive component.

To sum up, a positive impedance =  $R + jX$ , where  $+jX$  represents the +ve or -ve reactance of a positive component, a negative impedance =  $-R + jX$ , where  $+jX$  represents the +ve or -ve reactance of a negative component. With a given e.m.f. if a negative impedance is substituted for a similar positive one the only effect on the current is to turn it round  $180^\circ$ . Other combinations of resistance and reactance are unstable.

In his article "Cathode Ray" showed how a complex impedance could be represented by a simple impedance, that it was a definite advantage to know the phase angle, and it was because this angle was not known with complex waves that these waves had to be ruled out.

I quoted the formula  $\cos \phi = \text{True Power} / \text{Apparent Power} = \text{True Power} / EI$  so that this phase angle could be found in the case of a complex wave, for the evaluation of the impedance. It has no meaning when applied to the original wave. For instance, the current in the figure in "Cathode Ray's" reply could be delayed up to about  $90^\circ$  without affecting the power or this equivalent angle.

I am sorry that I incorrectly assumed that "Cathode Ray" had used "Ohm's Law" to show that a generator is equivalent to a negative resistance, but it is the only way I know of obtaining a value for resistance from a voltage and current. I also assumed that non-ohmic meant non-linear, but as the current does not affect the voltage in any way, perhaps non-resistive would have been better.

Mr. Head's Robinson Crusoe can actually provide a good analogy for negative resistance. When Robinson Crusoe rowed into a head wind he was slowed down by wind resistance. In a calm, the resistance was negligible. With a following wind, the resistance was negative, it might have been called positive assistance.

Binley, nr. Coventry.

D. L. CLAY

## Circuit Conventions

MR. L. H. BEDFORD'S letter in the April issue involves a subject which must be near to the heart of all readers of *Wireless World*.

Whilst I agree with most of the principles he suggests for drawing circuit diagrams, I find there are some statements in Mr. Bedford's letter which I cannot allow to go unchallenged. Surely the first principle should be not "to minimize interference to thought sequences," but to induce the correct thought sequences. With this in view, I consider valve envelopes to be a necessity. Mr. Bedford may well be able to assimilate all the information contained in a circuit diagram at one time, and as a whole, but if he can he is surely an exceptional man.

The valve envelope forms a visual and mental focusing point for all the components associated with a valve. One can look at such a circuit and immediately split it up into a mental block diagram, the amplifiers, oscillators, phase splitters, etc., being easily recognized. I say, without fear of contradiction, that this recognition is not possible without conscious mental effort if the distinguishing envelope is omitted. This also applies to transistors.

With regard to junctions, I always use the staggered T junction, without loops at crossover points. However, I prefer to see the loop used in *W.W.* It does not detract from the ease of reading a circuit diagram, and

removes any possible ambiguity. In conclusion, may I make a plea for a standard symbol for resistance in *W.W.*, preferably with just three "squiggles," no four or five, and for three-loop inductors.

Hounslow.

G. TILY.

MR. L. H. BEDFORD'S letter on the subject of circuit conventions is an admirable example of reasoned thinking on a topic which has caused anguish to us at some time.

Unfortunately your correspondent has made the common error of assuming that matters of terminology and drawing-office convention are compounded entirely of logic. These things are in fact heavily "loaded" with emotional aspects which we cannot ignore.

Take for example the envelope surrounding valve electrodes. Is it really superfluous in his Fig. 2? The valve is the king pin in each section of the circuit, and outlining this important component helps to break down an otherwise confusing jungle of L, C and R. To my mind, the most "comfortable" diagrams to read are those in which the valve envelopes are outlined very heavily, as for example the diagram on p. 184 of the same issue.

One possible remedy would be to adopt an entirely new valve symbol using heavy line work to replace the thin broken lines at present used to denote the grids. This would enable the valves to be seen at a glance, even without an encircling line.

But please, Mr. Editor, keep us from the characterless filigree of Fig. 3.

Idle, Bradford.

RAYMOND E. COOKE,  
Wharfedale Wireless Works Ltd.

MAY I please contribute to the correspondence initiated by Mr. L. H. Bedford and dealing with the subject of drawing symbols. My own interests and experience are concerned both with teaching and practical engineering.

In my student days, and still today, the processes of learning were and are unnecessarily complicated by lack of standards, poor standards and slipshod terminology. This is so for a student who is learning using his own language. How much more difficult it must be for students who come from other countries to study here!

British Standards are based upon the accumulated wide experience of the country's main engineering organizations, and all of us have everything to gain and nothing to lose by adopting them.

I started by using the conventions employed in your journal, but experience in trying to read from creased and dirty diagrams soon convinced me of the superiority of the British Standards conventions. I am surprised that Mr. Bedford should countenance the use of the X-junction. Perhaps he has always dealt with new, clean drawings. (I know that *Wireless World* has now abandoned its use, and uses only T junctions.)

But why does *Wireless World* retain the bridge? Consider a diagram in which a hundred wires going horizontally cross the same number going vertically. Must the draughtsman draw the *ten thousand* bridges? I know that *Wireless World* rarely, if ever, prints such diagrams, otherwise the problem would have been solved, but then we need the same conventions for large as for small diagrams.

I can assure you that a great number of practical circuit errors are made which are directly attributable to these dual standards, and that those organizations which support British Standards do so with much *application* experience behind them.

I disagree with Mr. Bedford about removing the "envelope" from the valve symbol.

I look forward to the complete banishment of the terms "condenser" and "choke," and the restriction of the terms "inductance" and "resistance" to the *property* and not the component involved.

As Mr. Bedford suggests, we make too much play with the conservatism of *others* (oh, yes, it's always *other* people who can't change). In actual fact, when one

is forced to do so, a change from driving on the left-hand side of the road to driving on the right is as simple as changing a purse from one pocket to another. A hundred years ago it probably didn't matter on which side you drove, but now it does, and if we don't like our driving laws it is up to us to complain to the appropriate authorities, but to adhere to the laws in the meantime. Similarly, I believe that we should all stick to British Standards, meanwhile endeavouring to change those that we do not like.

Sutton, Surrey.

R. C. WHITEHEAD

## Rogue Equipment

THE experience of "Diallist" recorded in your January issue under the sub-heading "Bewitched" is by no means unique.

I am responsible for the maintenance of about two thousand laboratory electronic instruments, and our record cards show that of, say, twenty oscilloscopes of one type, one or two are constantly in for service—mostly minor faults such as valve replacement, loose contacts on wafer switches, wiring discontinuities or short circuits, etc.—while the majority, used by the same engineers and technicians under the same conditions, are only rarely returned.

I have a theory to account for this and I would be interested to hear any views other readers may have about it.

Most instruments, radio and television sets, are, I believe, made in batches, maybe a hundred or a thousand or more, depending upon the type of apparatus. Sufficient components for a batch are drawn from stores, possibly with some spares, and put in bins or other containers along the assembly line.

At the beginning of the batch production goes smoothly and any weak components are randomly distributed so that early failures in the finished products made early in the run are rare, except they may be frequent of one kind due to poor design, e.g., a resistor being overloaded. Toward the end of the batch, however, the components that have visible faults such as resistors with leads badly bent (which have to be straightened with pliers and strained in the process), condensers that have fallen on the floor and rolled about in the dirt, wafer switches from the bottom of the bin whose contacts have been loosened by becoming entangled with others, in short all the components which have, possibly subconsciously, been rejected as imperfect by the operators early in the production, now have to be used. In some assemblies there may be the additional effect of hasty workmanship in order to complete the batch by a certain time to qualify for a production bonus.

These "last of the run" products are, I think, the ones with the built-in Gremlins.

Dolgelley.

A. HIMAN

## Signal-flow Diagrams

MR. RODDAM makes one mistake in his reduction of the signal-flow diagram (Fig. 3 of "Signal-Flow Diagrams" in the March issue). Although it is only a minor one, and does not affect the end result in this particular case, nevertheless I have found that the type of mistake is easily made, and can lead to error.

In converting Fig. 3(b) into Fig. 3(c), the arrow leading from node  $e_k$  to node  $e_{r1}$  is removed from  $e_{r1}$  and placed instead on  $i_1$ , with due change in the labelling of the branch. This is legitimate, but in Fig. 3(c) the node must no longer be labelled as  $e_{r1}$ . This is clear by the fact that Fig. 3(b) states that

$$e_{r1} = e_{in} - e_k$$

whilst Fig. 3(c) states that

$$e_{r1} = e_{in}$$

I have found the following two rules useful:—

(a) If the tail end of a branch is removed from a node A, it must be replaced by branches with tails coming from each node which feeds A, each with suit-

able labelling. No change in node labelling is to be made.

(b) If the head end of a branch is removed from node A, it must be replaced by branches with heads going to each node fed from node A, each with suitable labelling. The labelling of node A must be changed accordingly.

In the case of Mr. Roddam's Fig. 3(c), the labelling of the node " $e_{r1}$ " should be amended to " $e_{r1} + e_k$ ." Pinner.

S. TWEEDY

### The author replies:

The point made by Mr. Tweedy is sound, and it is only after some reflection that I would suggest that I have in fact not made a mistake but merely afforded an opportunity for others to fall into error. Once the diagram has been drawn the labels attached to internal nodes must be regarded only as identification marks, provided to aid in recognizing a rearrangement which may be made after a step in the reduction. If we wish to observe a particular internal node we must provide a test point which will appear as an external node and which will have only a single branch leading to it. Mr. Tweedy's rule (b) shows that this external node will never need a change of label.

I feel that this approach in which the system is treated as a multi-port network with input, output and inspection ports is not only formally more correct but also rather more economical as it avoids the labour of re-labelling nodes which are not accessible. Clearly we need to add a rule that output nodes for use as inspection ports must be provided before the reduction process begins and that thereafter internal nodes may not be inspected. In complex systems it might be convenient to provide new reference labels for these internal nodes so that they are not identified as signal values.

A similar loss in internal information occurs when we make use of the Strecker-Feldtkeller matrix algebra method, and I would suggest that the advantage of both these more sophisticated treatments of circuit problems is that they reduce the amount of unwanted information to be handled. From this point of view the rules suggested by Mr. Tweedy amount to an instruction to keep the bath water to avoid throwing out the baby.

THOMAS RODDAM

## Economical High-gain A.F. Amplification

CIRCUITS which work for other people don't always work for me. So it is nice to be warned in advance by Mr. Bailey's letter in the April issue that a "straight" pentode amplifier which provides him with a gain of 200 (*W.W.*, January 1960, p. 26) when its anode load is 147 k $\Omega$  won't give me a gain of 200 even with an anode load of 159 k $\Omega$ . On paper, however, the pentode will provide a gain in excess of 200, 3dB down at 10 kc/s, with a load of this value and a shunt capacitance of 100 pF, and by cascading the pentode and triode stages a gain of 8000 will be achievable.

The idea that the output impedance of all cathode-followers varies with the source impedance of the input voltage is quite incorrect. A glance at the accompanying figure, which gives the essentials of a cathode-follower, shows that there is no connection between the source  $V_s$ ,  $R_s$ , and the load  $R_L$ , except by way of the grid-cathode capacitance. At low frequencies, and with values of  $R_s$  up to a megohm or so, the effect of the capacitance is negligible, and the valve has an output resistance of  $r_a/(1+\mu) \approx 1/g_m$ .

G. W. SHORT  
Croydon.

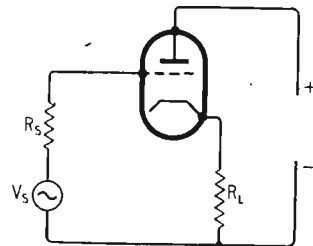

# Electronic Rocket Motors?

## ION AND PLASMA PROPULSION

**N**EWTON'S law of motion that the force on a body is given by the rate of change of its momentum becomes, for an isolated body like a rocket, that the force is given by the rate of loss of mass in the exhaust multiplied by the exhaust velocity. The rate of loss of mass, of course, determines the total mass of propellant material which must be carried in the rocket. Thus the propellant mass can only be reduced by increasing the exhaust velocity.

An upper limit to the exhaust velocity is set in chemical rockets when the chemical reaction which gives the greatest energy release is utilized. Unfortunately, even with this maximum exhaust velocity, most of the mass of the rocket has to be taken up with fuel.

Somewhat higher exhaust velocities than are possible with chemical rockets should be obtainable by heating the propellant in other ways, such as, for example, by a nuclear reactor, focused solar radiation or electrical arc or r.f. heating. However, the limit set by the melting point of the most refractory material usable as an exhaust nozzle or propellant container prevents any very great increase in exhaust velocities being obtainable by such alternative methods of heating the propellant.

The power consumed in the exhaust is proportional to the square of the exhaust velocity (for a given rate of loss of propellant mass), whereas, as we have seen, the force on the rocket is proportional only to the first power of the exhaust velocity. Now the power consumed will, of course, determine the mass of the power plant required. Thus, as the exhaust velocity is increased, the mass of the power plant required tends to increase much faster than the force on the rocket. Even when the decrease in the propellant mass required as the exhaust velocity is increased is allowed for, the total mass of the rocket tends to increase faster than the force on it. Hence, as the exhaust velocity is increased, the acceleration of the rocket tends to decrease. This decrease is, in fact, confirmed when particular propulsion processes are considered.

The acceleration required to leave the earth and achieve a satellite orbit can in fact only be achieved by means of chemical or nuclear reactor propulsion. The acceleration required to proceed beyond a satellite orbit is, however, very much less than the acceleration required to attain such an orbit. With the recent achievement of satellite orbits, other low-acceleration methods of rocket propulsion thus come into practical consideration. As we have seen, low-acceleration but high-exhaust-velocity propulsion systems allow an advantageous decrease in the proportion of the mass of the rocket which must be taken up by the propellant.

Propulsion systems offering exhaust velocities higher than are feasible using chemical or other methods of heating the propellant usually fall into one of two general types: the propellant is either in the form of ions which are accelerated by an electrostatic field, or it is in the form of neutral but fully

ionized gas (plasma) which is accelerated by the force produced by a magnetic field on currents driven through the plasma.

**Ion Propulsion.**—Nozzle heating limitations will not apply here, provided that interception by the electrodes of the ions is kept very small by accurate focusing.

To produce the maximum thrust for a given electric power, the mass to charge ratio of the ions should be as large as possible. One simple way of producing ions with a high mass to charge ratio is to cause the vapour of an alkali metal (such as caesium or rubidium) to come into contact with a hot surface made of a material (such as tungsten, platinum, molybdenum or tantalum) whose electron

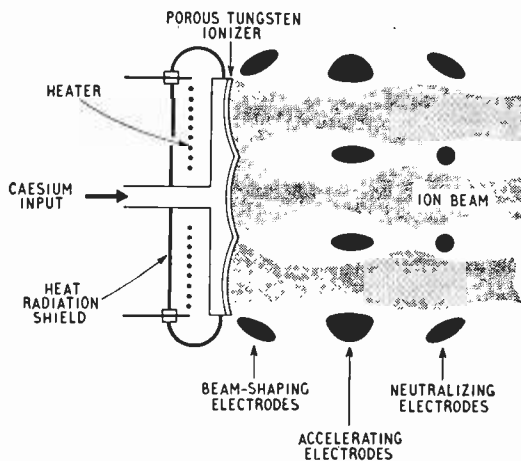

Fig. 1 Schematic of proposed ion propulsion motor. (Based on a figure in an article by A. T. Forrester and R. C. Speiser in the October 1959 issue of "Astronautics.")

emission work function is greater than the ionization potential of the alkali. Nearly all of the alkali atoms will then be ionized, provided that the temperature of the hot surface ionizer is greater than a certain critical value.

Advantages of this method of ionization are the freedom from erosion and thus long life of the ionizer, the high proportion of the alkali atoms ionized, and its simplicity and reliability.

The principal power loss in an ion propulsion motor employing this method of ionization is that consumed in heating the ionizer.

If the alkali vapour is simply passed over the hot surface or the ionizer then the incoming un-ionized alkali vapour will scatter and thus defocus the acceleration ions. This difficulty can be resolved by making the hot ionizer porous so that the alkali vapour can diffuse from beneath the hot surface. It can be shown that with this arrangement hardly

any neutral alkali atoms will leave the pore outlets, provided that the pores are made sufficiently small.

To prevent ion interception with consequent secondary emission, erosion and heating at the accelerating electrodes, very good focusing of the ion beam is necessary. A collimated beam is also desirable to maximize thrust. At this focusing accuracy, owing to space-charge defocusing effects, the required beam currents cannot be obtained in a single beam. A number of parallel beams will thus probably be required.

The ion beam must be neutralized after it has been accelerated, otherwise the rocket will charge up until no further ions can be ejected. An obvious way of neutralizing the ion beam is to use a thermionic emitter to inject electrons into the ion beam with the same vector velocity as the ions. Unfortunately, complications are produced because the electron velocities due to random thermal emission and to radial attraction towards the positive ion beam are then comparable or greater than the required velocity. The heater power lost in producing sufficient electrons from the thermionic emitter is a very small fraction of the ion beam power.

One suggested design of ion motor is described by A. T. Forrester and R. C. Speiser in the October 1959 issue of *Astronautics* (page 34), and a schematic of this design is shown in Fig. 1. Here caesium ions diffusing through porous tungsten are used. The tungsten ionizer surface is specially curved to help focus the strip ion beams. Electrons are thermionically emitted from part of the surface of the neutralizing electrodes. These electrodes are also made positive with respect to the accelerating electrodes. This prevents neutralizing electrons from bombarding the tungsten, although it also results in some deceleration of the positive ions. Heat radiation shields are provided to reduce radiation losses from the hot tungsten ionizer.

**Plasma Propulsion.**—Container and nozzle heating can be reduced in this system either by using magnetic fields to keep the plasma ions away from the walls or by linearly moving the plasma as far as possible rather than merely heating it.

Space-charge defocusing limitations which arise in ion propulsion are avoided by using plasma because the ion and electron densities are then everywhere essentially equal.

In plasma propulsion it is possible to consider the forces produced by magnetic fields on currents driven through the plasma in two ways, either from a large- or from a small-scale point of view.

From a large-scale point of view, the force produced by a magnetic field on a plasma current is given in magnitude by Ampère's law and in direction by Fleming's Left Hand Rule. In practical propulsion systems the magnetic field is often produced by the plasma current itself. The driving force is also often due to a difference between the magnetic fields on opposite sides of the plasma caused by curvature of the plasma current. Plasmas are also such good conductors that they are almost entirely prevented from crossing magnetic fields by the forces produced by interaction between these fields and the back e.m.f.'s set up in the plasma according to Lenz's law. Plasmas can thus be propelled by moving magnetic fields, and in some devices such fields are produced by the sudden increase in plasma current at the beginning of a discharge.

From the small-scale point of view, the inability

of plasmas to cross magnetic fields may be considered as being due to the fact that linear electron and ion motions become curled up on themselves into small cycloids by the action of the field. Plasmas also find it difficult to enter strong magnetic fields even by travelling along the field lines. This is because as the field increases more of the energy of linear motion of the ions and electrons becomes converted into energy of rotation about the field lines and the linear motion decreases. Because of this tendency to drift from strong to weak magnetic fields, plasmas behave rather like diamagnetic substances.

Losses in plasma rockets can arise in three places: at the electrodes, in the plasma itself, and at the plasma container walls.

Electrode losses may be produced in the voltage drops near the electrodes which are often associated

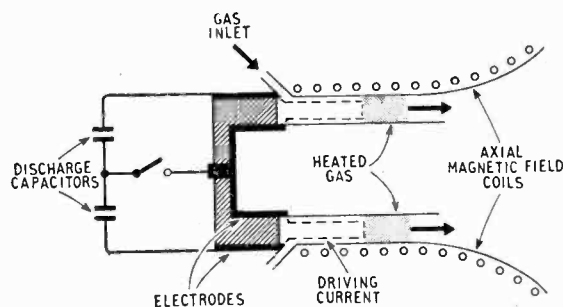

Fig. 2 Schematic of one proposed type of plasma shock propulsion motor. (Based on Fig. 7 of an article by M. Camac, A. Kantowitz and H. E. Petschek in the April 1959 issue of "I.R.E. Transactions on Military Electronics.")

with gas discharges. The relative importance of these losses can be reduced by ensuring that any such voltage drops near the electrodes are small compared with the voltage drop in the main body of the plasma. Fortunately, even though plasmas have a low resistance, this can be done without having to pass impossibly high currents because of the back e.m.f. produced by interaction between the moving plasma current and the magnetic field.

Losses in the plasma itself can occur due to ion recombination and cooling. The relative effect of these losses can be reduced by as far as possible directly linearly moving the plasma rather than merely heating it.

Losses to the container walls can be shown to be relatively more serious than in ordinary chemical rockets since in plasmas the power levels and densities are lower. However, these losses can be very much reduced by using magnetic fields to keep the plasma away from the walls.

The magnetic field required for reacting on the plasma current may be obtained in two ways, either directly as the field due to the plasma current itself, or from an external source. The latter method of obtaining the magnetic field is less preferable because of the extra mass and electrical heating losses in the field coils, though an ingenious suggestion for reducing the electrical loss is to make the coils superconductive by cooling them by exposure to outer space.

Motion due to magnetic fields generated by the plasma current itself occurs in transient rather than



steady state conditions. An obvious way of obtaining the required transient currents is by discharging a capacitor through the plasma. The construction of this capacitor then presents a number of problems, since it should have a low mass, high energy storage capacity, low loss, permit rapid and continual cycling, and be very reliable. Another problem likely to arise if transient discharges are used is that optimum pulse repetition rates are usually at audio frequencies, and such frequencies may produce fatigue in the rocket structure and possibly discomfort to a rocket crew.

A considerable number of plasma propulsion methods have been experimented with but most of these methods fall into one of two classes: a straight discharge in which the plasma motion is at right-angles to the discharge, or a contracting discharge in which the plasma motion is at right-angles to the direction of contraction.

A very simple type of straight discharge producing motion at right angles to the discharge may be obtained between the ends of two wire electrodes protruding from an insulator. An externally-provided magnetic field parallel to the wires can be used to confine motion to this direction. Alternatively, an external field at right angles to the plane of the two wires can be used to accelerate the discharge. In this case the insulator is dispensed with and the discharge starts between the ends of the two wires connected to the current supply and is accelerated by the field along the wires to their other ends. This rail accelerator, as it is called, should pulse itself due to the ejection of one plasma permitting the input voltage to rise until another discharge is struck.

Another type of straight discharge producing motion at right angles to the discharge can be obtained in a T-shaped tube. The discharge is struck between the ends of the (normally) horizontal arm of the T and plasma is then ejected down the vertical arm. Extra acceleration of the plasma can be produced by an externally-provided magnetic field perpendicular to both arms. Such a field could, for example, be produced by the return current from the discharge flowing in a suitably oriented coil.

Fig. 2 shows schematically a propulsion system described by M. Camac, A. Kantrowitz and H. E. Petshek in the *I.R.E. Transactions on Military Electronics* for April, 1959 (p. 39). This system utilizes a more complicated form of discharge producing motion at right angles to the discharge. Here the discharge is struck between two concentric cylinders and thus initially forms an annular sheet. As the discharge current grows, however, the path it takes expands down the space between the cylinders driving the gas in front of it (see Fig. 2). About half the energy goes into linearly moving the gas and half into heating it, some of the latter energy being recovered when the gas expands near the outlet. A weak externally-provided magnetic field along the cylinders' axis reduces plasma flow to the walls. Alternatively, a strong axial magnetic field may be used. This produces rotation of the plasma about the cylinders' axis which is then converted into motion along this axis as the gas expands near the outlet. In this modification, since the initial velocity of the plasma along the axis is lower, it spends a longer time in the initial accelerating region. The peak input power required is thus reduced. In this

modification the gas is injected radially at the inner rather than the outer cylinder.

One type of contracting discharge may be produced in a discharge tube round which is wound a single-turn coil. A rapidly-increasing current in the coil produces an electric field which breaks down the gas in the tube to give circular discharge currents in the opposite direction but parallel to that in the single turn. The current in the coil also produces a magnetic field along the discharge tube axis which drives the plasma inwards towards this axis and thus propels the plasma along the tube.

Another type of contracting discharge is the cylindrical pinch discharge struck between two facing disc electrodes. This produces a contraction towards the cylinder axis due to the attraction between the various like currents out of which the discharge may be regarded as being composed. If a hole is made in the centre of one of the electrodes, the compressed plasma will be forced out through this hole along the cylinder axis. In practice the disc electrodes may be shaped to further direct the flow.

Thermonuclear reaction propulsion is somewhat similar to plasma propulsion in that magnetic fields are used to direct the ionized reacting material—in this case away from the reacting walls. One possible system utilizes the contracting cylindrical pinch discharge just discussed, the reacting material being heated by the discharge current. Other systems necessitate heavy magnetic field coils.

Advantages common to both plasma and ion rockets are the possibilities of exactly controlling the thrust and of using the power source (which in these systems is electrical) to supply the radio transmitter when the rocket motor is switched off.

The highest possible exhaust velocity is achieved when light is emitted as the exhaust. Calculations show, however, that the thrust achievable with light will not be capable of providing anything like even the small acceleration required for proceeding beyond a satellite orbit.

## REFERENCES

- I.R.E. Transactions on Military Electronics*: April, 1959.  
*Astronautics*: October, 1959.  
*Electronics*: April 24, 1959, pp. 69-71.

## Amateur Exam. Results

THE examiners report that the general standard of work by the 1,131 candidates who entered for the Radio Amateurs' Examination, conducted by the City and Guilds of London Institute last year, was considerably lower than in previous years. As will be seen from the following table, the number of entrants was more than twice the total of 1956, but the percentage of passes among U.K. candidates has decreased considerably.

	1959	1958	1957	1956
<b>U.K. Candidates</b>				
Passed ...	657 (59.6%)	518 (72.3%)	377 (67.1%)	458 (88.4%)
Failed ...	445 (40.4%)	198 (27.7%)	185 (32.9%)	60 (11.6%)
Total ...	1102	716	562	518
<b>Overseas Candidates</b>				
Passed ...	18 (62.1%)	3 (60%)	4 (50%)	5 (62.5%)
Failed ...	11 (37.9%)	2 (40%)	4 (50%)	3 (37.5%)
Total ...	29	5	8	8

# Time Interval Measurement

An Interesting Application of the Airmec Timer to  
the Setting up of the Decca Navigator System

By J. CARMICHAEL, B.Sc.

**T**HE Decca Navigator transmission system comprises one Master and three slave stations, referred to as Red, Green and Purple. When the transmissions from the Master station and any slave station are reduced to a common comparison frequency in a receiver, it is found that a series of hyperbolic lines of phase coincidence is formed between the two stations. The location of all four stations being known, the lines of phase coincidence become posi-

acy inherent in the very fine pattern is bought initially at the expense of multiple ambiguity, in that exactly similar phase relationships are repeated in every lane. Where the readings start from a known datum and there is no interruption in the use of the equipment, the lane counters provide an unequivocal answer. In many cases, however, particularly where aircraft are concerned, it is necessary that any ambiguity be resolved automatically and continuously. This is done by superimposing on the normal pattern at intervals a further "coarse" pattern produced by signals of lower frequency.

The normal transmission frequencies for Purple, Master, Red and Green transmitters are related in the ratio  $5f$ ,  $6f$ ,  $8f$  and  $9f$  respectively where  $f$  is the common basic frequency. In the latest Mk. 10 equipment the lane identification pattern is produced by arranging that each station in turn radiates all four frequencies for a brief period every minute. The effect, shown in Fig. 2, is to generate in the receiver a complex waveform incorporating a well-defined  $f$  peak, which can easily be differentiated from spurious signals. The coarse pattern, superimposed on the three fine patterns in turn, embraces between eighteen and thirty fine lanes, the lane identification needle being actuated in the same way as the fine pattern needle.

**Zone Identification.**—The remaining ambiguity, where a large area is concerned, is resolved by the inclusion of a further  $8.2f$  component in the lane identification signals which, in conjunction with the  $8f$  component, generates a  $0.2f$  "zone identification" pattern. This is five times coarser than the lane identification pattern, indication being provided by a further pointer. In practice, ambiguity is now removed within an area so large that even very high-speed aircraft can obtain a certain fix immediately on entering Decca coverage, without reference to any other datum.

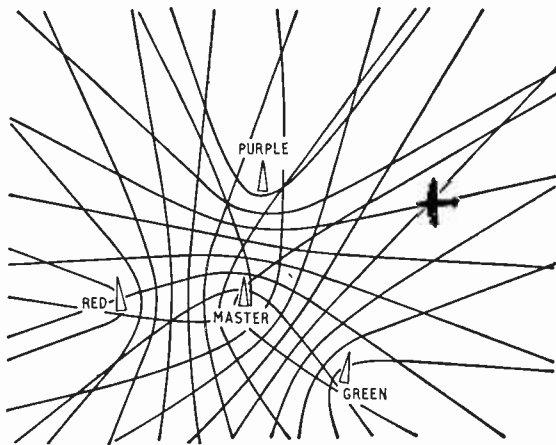

Fig. 1. The Decca principle. Hyperbolae of phase coincidence between Master and slave stations are detected by a form of phase meter in a receiver. Any two readings give a "fix" which, under best conditions, may be accurate to within a few yards.

tion lines which can be superimposed on a map of the area covered by the system. The location of a ship or aircraft can then be determined by identifying two lines at a point of intersection. The line pattern is shown in Fig. 1, the position of the aircraft in this case being fixed with reference to a Purple and a Green position line.

The transmission frequencies are so chosen that, at the comparison frequency, the minimum lateral spacing of in-phase lines directly between the two stations (constituting a Decca "lane") is about 450 yards. The phase difference at points between the lines is detected by a "Decometer," which is simply a phase-meter with a 360-degree scale calibrated in 100 divisions. Under favourable conditions it is possible to determine one's position line within a lane to within  $4\frac{1}{2}$  yards. The actual lane is primarily shown by the lane indicator on the "Decometer," which counts one lane for every complete rotation of the main hand, starting from a known datum. By determining one's position line on any two of the master-slave patterns, an accurate fix is obtained.

**Ambiguity.**—The unusually high degree of accu-

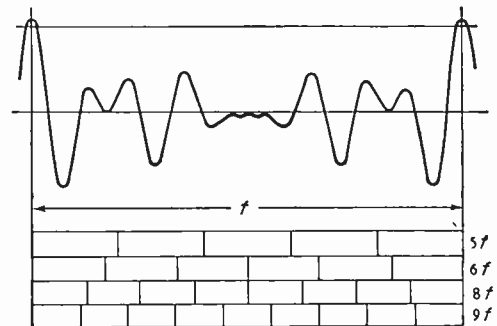

Fig. 2. The combination of all four frequencies sent out by each station in turn generates this lane identification pulse at the receiver. The main peaks, at  $f$ , create a coarse navigational pattern to reduce ambiguity.

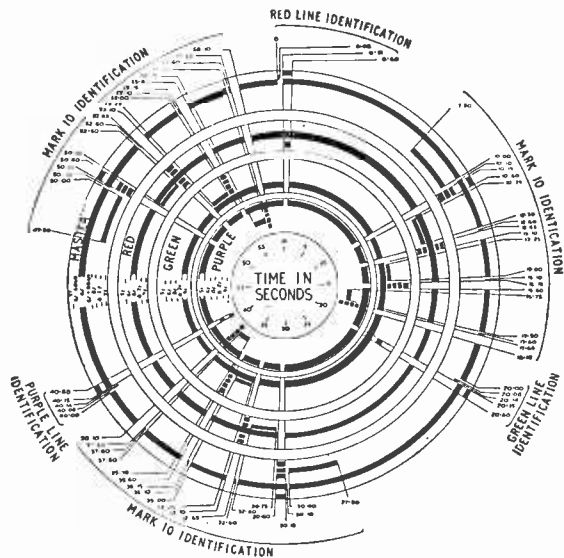

Fig. 3. The complex timing sequence of the four transmitters in a Decca chain. All frequencies and timing are controlled by the Master station. The timing, embracing periods of as little as 60 milliseconds, is electronically checked.

**Importance of Timing.**—All transmitters are locked to the Master station, which incorporates the necessary crystals for all the required frequencies. The new lane identification technique calls for a very accurate timing sequence, initiated by the Master station, to trigger the many combinations of transmission required to produce the identification pulses. Just how complicated the transmission pattern is may be gathered from Fig. 3, which shows the complete one-minute cyclic programme on a circular time base. The transmissions of all four stations are shown by concentric bands. On the Master transmitter, additional pulses at  $6f + 60$  c/s and  $6f - 60$  c/s are included. These form triggering pulses to initiate switching sequences in the receivers, and to synchronize lane identification pulses at the slave stations. Timing for all transmissions is derived initially from a synchronous clock driven by the Master  $6f$  oscillator through a suitable frequency divider. Switching is performed by multiple contacts operated by a clock-driven cam, the contacts in turn operating relays which perform the individual switching operations.

The need for accurate control of the time intervals is obvious; any mistiming, especially false overlapping of transmissions, would result in grossly misleading signals being received. The lane identification pulses in particular could easily be made unrecognizable by slight timing maladjustment. High-speed relays lightly loaded ensure that initial performance is maintained, but great care must be taken with the initial setting-up to establish the contact operating points accurately and to ensure that no undesirable lags are introduced by time delays in subsequent electronic circuitry.

**Electronic Timer.**—The work of measuring and checking all the time intervals is greatly simplified by the use of electronic methods. The instrument used is a Type 771 Time Interval Meter made by Airmec Ltd., of High Wycombe, Bucks. It is

designed to measure with a high degree of accuracy any time interval between 10 milliseconds and one minute, and the timing sequence can be triggered by a wide variety of electrical functions. Two pairs of terminals are provided for connection to the circuits to be checked, and a simple rotary switching arrangement selects the required function. Examples of the intervals which may be measured include the duration of make of a contact, the duration of break, the delay between the making of a contact and the closing of a relay and the interval between the making or breaking of one contact and the making or breaking of another contact, as well as numerous permutations of these functions.

In Fig. 4, the meter is shown connected to the anode circuit of the drive valve in the Master transmitter control rack to check the duration of the "Green plus 60 c/s" transmission which occurs twice per minute during the Purple and Green lane identification pulses. The duration of these signals is critical at only 60 milliseconds, for which time the drive valve is made conductive by grid control. The connection is made to the Contact I terminals of the timer, and the valve used as a "making" contact which passes the timer current while operating. The absolute maximum tolerance on this period is 5 milliseconds, but in practice it is generally held within much finer limits. The accuracy and stability of the meter are here invaluable, for the specified accuracy is within  $\pm 3\%$  of full scale, equivalent to  $\pm 3$  milliseconds. Initial high-speed film checks carried out by Decca have shown that the guaran-

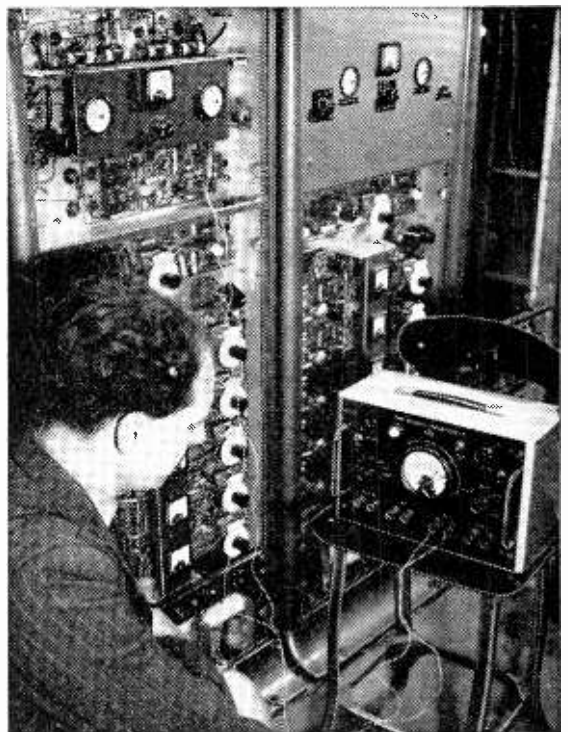

Fig. 4. Using the Airmec time interval meter to measure the duration of the 60 millisecond transmission at  $6f + 60$  c/s on the Master station. The Airmec timer is triggered by the anode circuit of the appropriate drive valve.



Fig. 5. The timer is also used to check the relay characteristics and timing circuits in the Decca receiver. In this case the Mk 10 lane identification chassis is being timed.

teed performance is considerably exceeded in practice.

**Simple Principle.**—The consistent and accurate performance of the meter is largely due to the use of all-electronic measuring techniques, without the complications and inertia effects introduced by mechanical elements. The circuit consists of a series of high-stability resistors which are switched across a capacitor by the circuit to be measured. The capacitor, which has been pre-charged to a given potential, is partly discharged to an extent dictated by the time interval and the resistor value, and its terminal voltage is applied to the grid of a single under-run amplifier valve. The valve anode current, stabilized by cathode negative feedback, is dependent only on the grid potential and can be measured on the display milliammeter, which is calibrated directly in units of time. The resistor value depends, of course, on the interval range selected, the total range being divided into seven sections.

The reading is independent of the actual value of initial charge, this being taken care of by a "set infinity" adjustment which is made when the meter indicates full charge before the timing sequence is initiated. Unless serious changes in mains voltage are liable to occur while readings are being taken, it is not necessary to repeat the infinity setting for individual readings. This saves a good deal of time when, as in the present case, repeated readings are being taken. Low leakage losses mean that the meter reading is maintained for at least thirty seconds, allowing plenty of time to record readings; a number of short intervals may in fact be totalled where the aggregate of separate time intervals is required.

**Receiver Timing.**—The need for accurate timing is no less on the Decca receiver than in the case of the transmitter. Complex switching is required to sort out the various signals to the different phase-

measuring circuits, and ultimately to the individual "Decometers" during the identification periods. Switching is carried out on the identification chassis, shown in Fig. 5, by a number of relays incorporating various time delays down to about 0.5 seconds. The delay between energizing and actual operation of the relays must also be checked.

The time interval meter has proved a most convenient way of checking the hundreds of different time functions on the Decca Mk. 10 equipment. The transmitter control units are housed in tall racks, and the light weight of the instrument (15½ lb) facilitates its use on some of the more remote circuits. Apart from the normal production and setting-up checks, it is also used

in the field for service work, where its independence of any form of stabilized mains voltage or frequency is a great advantage.

### "Personal" Direction Finder

DESIGNED for marching or steering in the direction of known radio beacons, for example, during rescue work in catastrophes in mountainous areas in low visibility, the Telefunken miniature direction finder can be worn on the person and can be operated either by aural signals or by a signal strength meter worn like a wrist-watch, thus giving complete freedom of movement. The

unit, which measures 156 x 116 x 56mm and weighs just over 1kg, makes use of sub-miniature valves and transistors. By means of interchangeable cartridge coils it covers 57kc/s to 20M/cs in ten ranges.

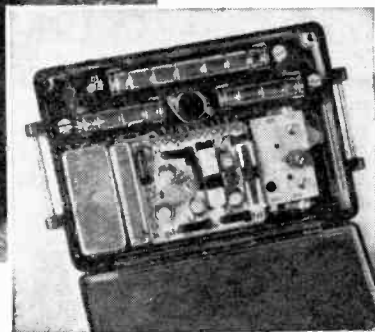



Model W.V.A.

## TAPE RECORDERS

The W.V.A. tape recorder now has provision for Stereo plug in heads to enable this recorder to replay Stereo. The regular models are retained with additions and improvements. Our high standard which has made these recorders famous has been maintained, resulting in their being chosen for the foremost musical centre in this country.

## 30/50 WATT AMPLIFIER

Gives 30 watts continuous signal and 50 watts peak Audio. With voice coil feedback distortion is under 0.1% and when arranged for tertiary feedback and 100 volt line it is under 0.15%. The hum and noise is better than -85 dB referred to 30 watt.

It is available in our standard steel case with Baxendale tone controls and up to 4 mixed inputs, which may be balanced line 30 ohm microphones or equalised P.U.s to choice.

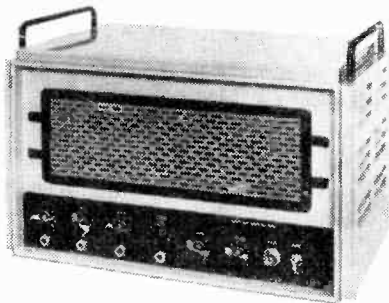

## ELECTRONIC MIXER/AMPLIFIER

This high fidelity 10/15 watt Ultra Linear Amplifier has a built-in mixer and Baxendale tone controls. The standard model has 4 inputs, two for balanced 30 ohm microphones, one for pick-up C.C.I.R. compensated and one for tape or radio input. Alternative or additional inputs are available to special order. A feed direct out from the mixer is standard and output impedances of 4-8-16 ohms or 100 volt line are to choice. All inputs and outputs are at the rear and it has been designed for cool continuous operation either on 19 x 7in. rack panel form or in standard ventilated steel case.

Size 18 x 7½ x 9½ in. deep.

Price of standard model £49.

Also 3-way mixers and Peak Programme Meters.

4-way mixers.

12-way mixers, and 2 x 5-way stereo mixers with outputs for echo chambers, etc. Details on request.

*Full details and prices of the above on request*

**VORTEXION LIMITED, 257-263 The Broadway, Wimbledon, London, S.W.19**

Telephones: LIBerty 2814 and 6242-3

Telegrams: "Vortexion, Wimble, London."

# Vortexion

quality equipment

## 120/200 WATT AMPLIFIER

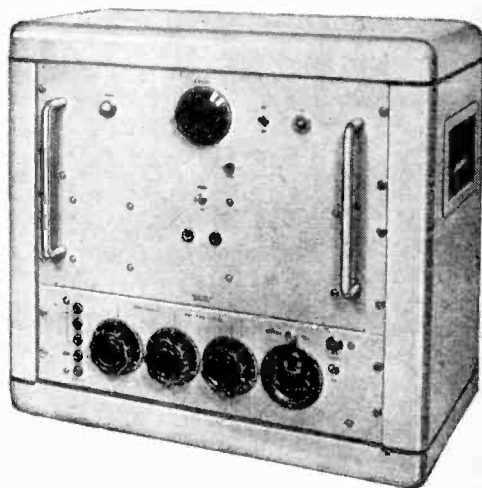

Will deliver 120 watts continuous signal and over 200 watts peak Audio. It is completely stable with any type of load and may be used to drive motors or other devices to over 120 watts at frequencies from 20,000 down to 30 cps in standard form or other frequencies to order. The distortion is less than 0.2% and the noise level -95 dB. A floating series parallel output is provided for 100-120 V. or 200-250 V. and this cool running amplifier occupies 12½ inches of standard rack space by 11 inches deep. Weight 60lb.

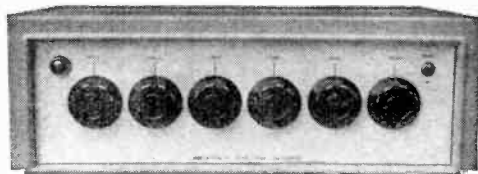

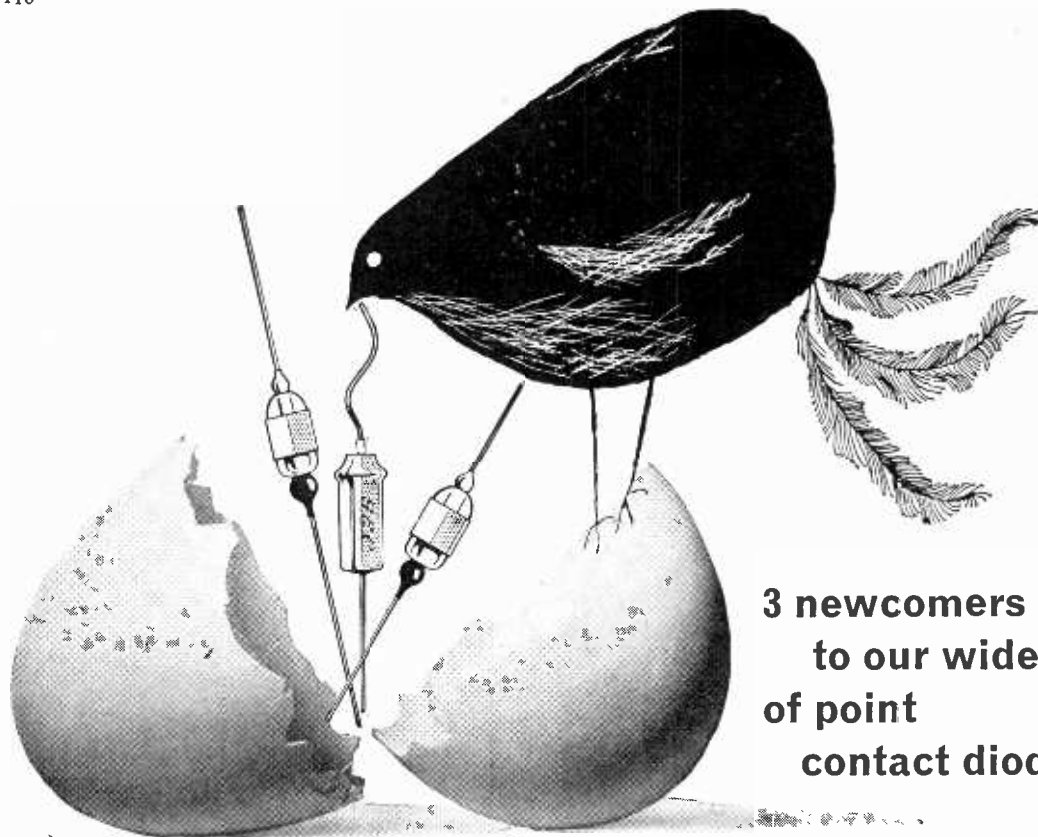

**3 newcomers  
to our wide range  
of point  
contact diodes**

**GEX37** High efficiency r.f. diode also suitable for low level vision detection. Turnover voltage greater than 30. 68% average rectification efficiency with 600 $\mu$ A min. rectified current at 35Mc/s into a 6.8k load.

**GEX58** Diode with high back resistance maintained up to -100V. Turnover voltage greater than 120. Max. current at -100V (Tamb. = 60°C.) is 450  $\mu$ A.

**GEX942** Gold bonded germanium diode with a low forward voltage drop, typically 0.65V at 100mA. It has a short reverse recovery time, low capacitance and may be used up to 75°C. GEX941 is a single ended version of this diode.

**CURRENT GERMANIUM POINT CONTACT DIODES**

	<b>GEX34</b> General Purpose diode	<b>GEX39</b> High efficiency r.f. and high speed switching diode	<b>GEX36</b> { (CV2310) Modulators for telephony. Can be supplied in quads matched for fwd. voltage at 5mA. <b>GEX64</b> {
	<b>GEX35</b> Low level vision detector	<b>GEX45/1</b> General purpose diode (CV 425)	
		<b>GEX54</b> High back resistance diode (CV 448)	

**RADAR MIXER DIODES**

	<b>GEM1</b> { Germanium co-axial low noise X-band mixer. Extremely low X-band noise factor of 7.5dB. <b>GEM2</b> {	<b>SIM3</b> { Silicon co-axial X-band mixers <b>SIM6</b> {		<b>SIM8</b> { Silicon waveguide Q-band mixers (CV 2391) <b>SIM9</b> { (CV 2392)
	<b>SIM2</b> { Silicon co-axial X, S and L band mixers (CV 2154) <b>SIM5</b> { (CV 2155)			



**SEMICONDUCTORS**

For full information on these and many other types, please write to:—  
 G.E.C. Semiconductor Division, School Street, Hazel Grove, Stockport, Cheshire.  
 Telephone: Stepping Hill 3811 or for London Area ring Temple Bar 8000, Extension 10

# Elements of Electronic Circuits

## 13.—THE PUCKLE TIMEBASE

By J. M. PETERS, B.Sc. (Eng.), A.M.I.E.E., A.M.Brit.I.R.E.

**A** WIDELY used timebase generator of the freely-running relaxation-oscillator type is the Puckle timebase, named after its inventor O. S. Puckle. It is based on the multivibrator but has direct coupling between one anode and the opposite grid. Fig. 1 shows the basic arrangement. V1 and V2 form the relaxation oscillator, while V3 is the "constant current" pentode (see last month's instalment) for providing linear charging of the timebase capacitor  $C_3$ . The action will be described with reference to the waveform diagram Fig. 2.

### Stage A (The Sweep Period):

It is assumed that initially the voltage at V2 cathode is near h.t. and that  $C_3$  is charging linearly through V3. V1 is conducting and a large voltage drop occurs across  $R_1$ , which makes the control grid of V2 negative with respect to its cathode, thereby cutting off V2. The voltage at V2 cathode falls until it reaches that of V2 control grid; V2 then conducts.

The voltages at V2 anode and V1 suppressor grid fall. This causes V1 anode to rise and to take the control grid of V2 with it. V2 grid is by now considerably more positive than V2 cathode, therefore a further increase in V2 current results. A cumulative action follows until, with V2 conducting heavily, the anode current of V1 is cut off. The voltage at V1 anode rises towards h.t.

### Stage B (The Flyback Period):

During this interval  $C_3$  discharges through the conducting V2 and  $R_2$ , and V3 anode returns to

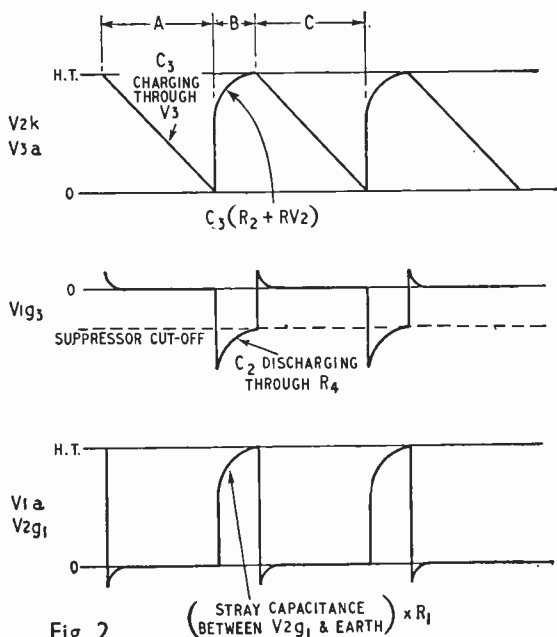

Fig. 2

h.t.  $C_2$ , now discharging towards zero volts, reaches the V1 suppressor grid cut-off point and anode current begins to flow again in V1. This causes the voltage at V1 anode and V2 grid to fall. The current in V2 starts to fall and the voltages at V2 anode and V1 suppressor rise. This cumulative action continues until V2 is cut off and V1 is conducting heavily.

### Stage C:

At the start of this interval  $C_3$  is discharged (both plates at h.t. potential).  $C_3$  now charges through V3, and V3 anode returns towards earth potential.

It is possible to synchronize the timebase to an external signal, which can be applied to the control grid of V1 (or to the anode of V2). In some variants of the circuit the connections to V1 control grid and suppressor may be found to be interchanged. Use is often made of the negative pulse which appears at the anode

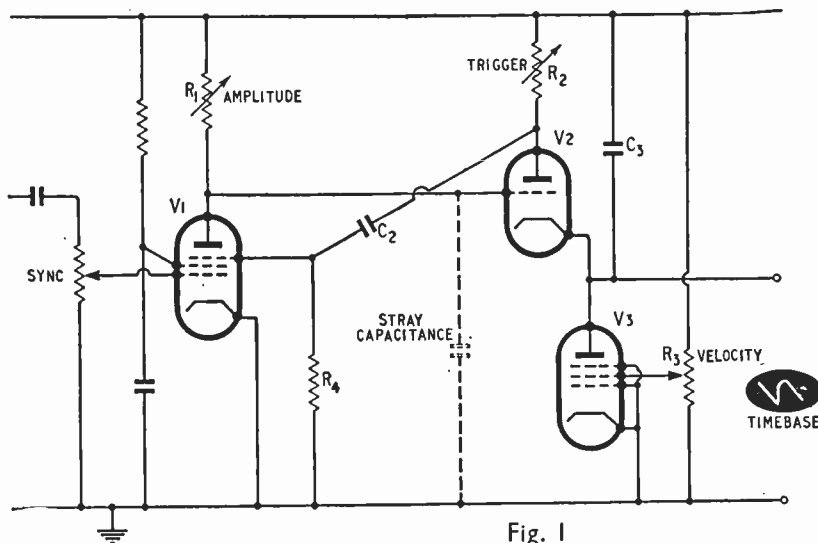

Fig. 1

of V2 during the flyback period. It is taken to the cathode-ray tube to turn off the electron beam during this period, thus eliminating the unwanted trace produced by the spot on the tube face due to the flyback voltage.

R<sub>1</sub> controls the amplitude of the timebase voltage. The amplitude of the voltage at V3 anode is determined by the voltage on V2 control grid since V2 acts as a cathode follower. R<sub>2</sub> controls the duration

of the flyback voltage (Interval B) which is governed largely by the time constant C<sub>3</sub> (R<sub>2</sub> + resistance of V2). It also determines the amplitude of the voltage variations at V2 anode and V1 suppressor grid. R<sub>2</sub> is known as the trigger control. The value of the "constant current" in V3 is controlled by its screen voltage and R<sub>3</sub> is known as the velocity control. The maximum repetition frequency is determined by the flyback period (Stage B).

## PRODUCTION OF METAL-FILM RESISTORS

DETAILS OF ITALIAN PROCESS APPLIED IN U.K.

NICKEL-CHROMIUM film resistors, marketed under the name Metallux, have in the past been imported from Italy by Plessey Co., Ltd. However, Elettronica Metal Lux s.p.a., of Milan, have recently co-operated with Plessey in the installation of production equipment at the Plessey works at Kembrey Street, Swindon.

In the production of Metallux resistors a vacuum-coating process is used. Ceramic formers with silver-coated ends are loaded on to spindles which are then transferred to a round jig holding between 100 and 700 formers, the actual number depending on the power rating. The jig is then placed under a vacuum "bell" and the pressure inside is reduced to about  $3 \times 10^{-4}$  torr (mm mercury): this takes about an hour. Four crucibles

achieved by grinding away the coating to form an insulating track, which may take either a spiral or axial form depending on whether high resistance values or non-inductive resistors are required. The grinding machine stops automatically when the required resistance is reached.

Finally connecting wires are soldered to the metallized ends of the former: the whole is given the required surface finish, which may range from another coat of varnish to a sealing in a ceramic tube, and a last test is made.

Resistances range between  $0.1\Omega$  and  $2M\Omega$ , power ratings between  $\frac{1}{8}$  and 4W. Voltage coefficients depend on power rating but are between 0.0003 and 0.00005%/V and maximum temperature coefficients run from less than  $\pm 0.02\%/^{\circ}C$  to  $\pm 0.0015\%/^{\circ}C$  whilst a 1,000-hr stability test reveals a worst stability of 0.35%. Marked improvements are claimed on reduced load and for the fine temperature coefficient types. A low noise level is, naturally, achieved and the impedance of the non-inductive types differs by less than 5% at 1 Gc/s (1,000Mc/s) from the resistance.

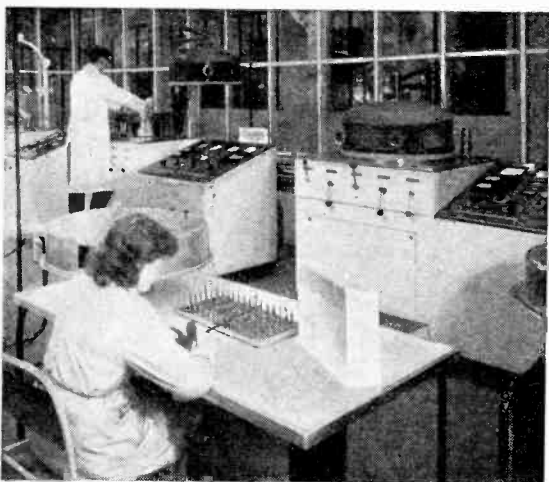

Part of Metallux resistor production shop showing coating machines and the painting-on of protective silicone varnish.

placed under the jig and containing nickel-chromium alloy are heated rapidly to about  $1,600^{\circ}C$ , when the nickel-chromium alloy begins to evaporate on to the formers. To ensure even coating, the formers are themselves rotated as the jig rotates; shaped masks over the crucibles also help. The coating process is stopped when the required value of resistance, known as the "pre-value," is reached on a specimen former. At this stage the coated formers are painted with a protective silicone varnish, baked at a high temperature and stored, after being graded for temperature coefficient and "pre-value."

When a particular value of resistance is required, suitable "pre-values" are chosen and, in the same way that cracked-carbon resistors are made, the final value is

### BAND NUMBERING

FOR some years now the television and sound broadcasting bands between 41 and 216Mc/s have been given the numbers I (41—68), II (87.5—100), and III (174—216) and those above 400Mc/s as numbers IV (470—585) and V (610—960). Indeed, this nomenclature has been used in international agreements, as, for instance, in the Final Acts of the Stockholm European Broadcasting Conference (1952). It is surprising, therefore, to find that in adopting a series of numbers for the identification of frequency bands at the recent Geneva Conference some of the numbers already in use have been duplicated. This can only lead to confusion.

It will be seen from the table below, which is based on the Geneva "Final Acts," that there is now an additional waveband—decimillimetric waves—and that the abbreviation Tc/s (teracycles) is used. It will also be noticed that the planners have run out of superlatives for this band. The lower limit quoted for each band is excluded but the upper limit is included.

Frequency Band	Frequency range	Waveband	Band Number
v.l.f.	3—30 kc/s	Myriametric	4
l.f.	30—300 kc/s	Kilometric	5
m.f.	300—3,000 kc/s	Hectometric	6
h.f.	3—30 Mc/s	Decametric	7
v.h.f.	30—300 Mc/s	Metric	8
u.h.f.	300—3,000 Mc/s	Decimetric	9
s.h.f.	3—30 Gc/s	Centimetric	10
e.h.f.	30—300 Gc/s	Millimetric	11
	300—3,000 Gc/s or 3 Tc/s	Decimillimetric	12



# Manufacturers' Products

## NEW ELECTRONIC EQUIPMENT AND ACCESSORIES

### Hermetically-sealed Potentiometers

TO the moulded-track range of potentiometers produced by Plessey has now been added a new hermetically-sealed type known as the XP5. It is said to be entirely moisture proof and conforms with Inter-Services standards for components of this type.

Sealing is effected by bringing out the three contacts through ceramic seals on the back of the metal case

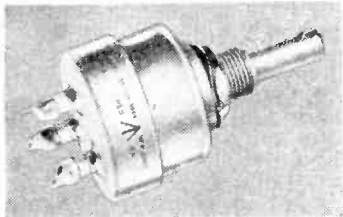

Plessey hermetically-sealed potentiometer Type XP5

and by the use of Neoprene rings seated in channels packed with anti-freeze grease fitted to the control spindle. A Neoprene sealing washer is used also to provide a panel seal.

Normal working range of temperatures is  $-40^{\circ}\text{C}$  to  $+70^{\circ}\text{C}$  and the resistance values available extend from  $500\Omega$  to  $2.5\text{M}\Omega$ , either linear or logarithmic law. A limit of  $500\text{V}$  d.c. across the resistance element is imposed.

The makers are Plessey Co. Ltd., Vicarage Lane, Ilford, Essex.

### Audio-frequency Filter

WITH the Dawe Type 1465 variable high-, low- or band-pass filter characteristics can be obtained. Tuning is effected by varying an inductance by moving a blade of magnetic material across the face of the core of the inductance. Outside the pass band the attenuation is at least 23dB an octave above the 3dB cut-off frequency, and the attenuation exceeds 23dB at any frequency beyond this octave. The insertion loss inside the pass band increases from zero to 1dB at half or double the cut-off frequency in the case of low or high-pass filters respectively; in the case of a band-pass filter the insertion loss is the sum of the two losses due to the high-

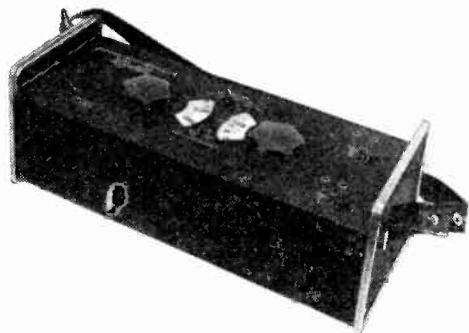

Dawe Type 1465 audio-frequency filter

and low-pass filter which together form the band-pass filter. The high- and low-pass cut-off frequencies can be independently varied from 20c/s to 20,000c/s. The filter is passive and so requires no power supply. The 1465 costs £158 and is manufactured by Dawe Instruments Ltd., of 99 Uxbridge Road, London, W.5.

### Loudspeaker and Earphone Control Unit

THE Rai-tel-aid Mark 2 is designed for the hard of hearing and those who desire personal listening to wireless, gramophone or television. It consists of a small control box carrying volume and tone (bass-cut switch) controls for the earphone (which fits onto the individual's ear mould) and a changeover switch which enables a 4-W,  $3\Omega$  dummy load to be substituted for the loudspeaker in the receiver or record player. Safety in operation is ensured by the use of an isolating transformer with an earthed screen between the windings. The four-core cable connecting the control box to the set is terminated in a plug mating with a socket on the set and a "dummy" plug is provided so that the Rai-tel-aid may be transferred from one piece of apparatus to another without interrupting normal use.

The Rai-tel-aid Mark 2 costs £5 5s from Electric Ades, Ltd., of 4 Eastbourne Road, Hanworth, Middlesex.

### Locking Knob

THE facility for locking a control after adjustment has been effected is a useful one in certain test gear and electronic equipments and a knob of this kind is now obtainable from General Controls Ltd., 13-15 Bowlers Croft, Honeywood Road, Basildon, Essex. It can be locked in any position over a rotation of  $330^{\circ}$ . Normally the skirt of the knob is blank but it can be engraved to specific requirements. Finished in gunmetal grey the knob measures  $1\frac{1}{2}$ in overall diameter and  $\frac{1}{8}$ in deep.

### Miniature Indicating Dial

THE small indicating dial shown in the illustration registers whole revolutions and fractions of a turn of the spindle on which it is fitted. While intended primarily for the miniature helical potentiometers made by General Controls it nevertheless has many applications wherever a precision, multi-turn indicating dial is required.

These dials are machined from solid Duralumin with

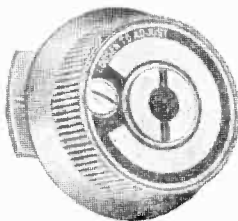

Above: General Controls skirted locking knob with integral datum line indicator.

Below: General Controls miniature indicating dial fitted to a small helical potentiometer.

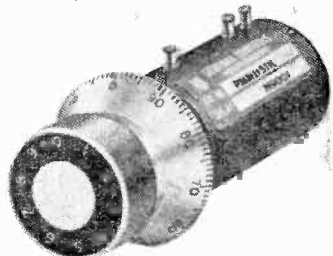

the skirting engraved 0-100 (fractions of a turn) and models are available registering from 3 to 10 complete revolutions as required. The diameter of the engraved skirt is  $1\frac{5}{8}$ -in and the overall depth is  $\frac{3}{4}$ -in. It fits  $\frac{1}{8}$ -in spindles.

Further details are obtainable from General Controls, Ltd., 13-15 Bowlers Croft, Honywood Road, Basildon, Essex.

### Multiple Galvanometer

THE Rugalvo 26 enables photographic recordings of up to twenty six varying currents to be made simultaneously and has many possible applications in physiological and geophysical research. A wide variety of movements is available with coil resistances of 7 to 900 $\Omega$  and natural resonances of 5 to 700c/s. A single

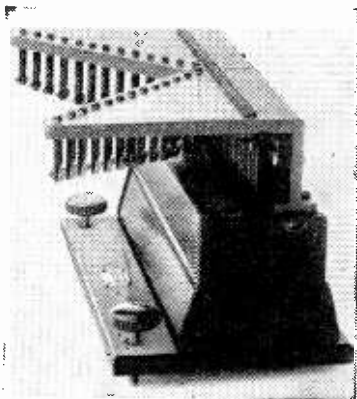

Rugalvo 26 multiple galvanometer.

light source is used to illuminate the galvanometer mirrors and the returning beams are directed into the photographic recorder by adjustable fixed mirrors. A single magnet system provides the field for all the movements.

Agents in the U.K. for this galvanometer, which is of German manufacture, are British Sarozal Ltd., 22 Berners Street, London, W.1.

### V.H.F. Wave Analyser

THE Airmec Type 248 can measure signal frequencies from 5Mc/s to 300Mc/s to an accuracy of  $\pm 2\%$ , and signal levels from 5 $\mu$ V to 1.5V r.m.s. from a 75- $\Omega$  source. Levels up to 15mV are measured using an i.f. attenuator variable up to 70dB in 2dB steps and also an output meter calibrated from -2dB to +2dB for interpolating between these steps. For measuring levels above 15mV, two 20dB r.f. attenuators are also used. The maximum error due to variation of instrument sensitivity with frequency is  $\pm 1.5$ dB, that due to instrument noise is 3dB at an input level of 5 $\mu$ V, and that due to a 10% change in the mains supply voltage is  $\pm 1$ dB. The maximum error in the i.f. attenuator is

$\pm 1$ dB, that in the two r.f. attenuators rises with frequency to a maximum of  $\pm 1.5$ dB in each at 300Mc/s. Three alternative i.f. passbands are provided. These are 3dB down at 15kc/s and 35, 85 or 515kc/s and 50dB down at 80, 170 or 1500kc/s respectively. Second and third harmonic levels can be measured down to -55 and -70dB respectively relative to the fundamental level. As may be seen from the i.f. bandpass frequencies, a very low i.f. is used. This has a number of advantages: there are no gaps in the frequency coverage due to the i.f. falling within the operating range, the i.f. attenuators can be made more accurate, and the sides of the i.f. response curve steeper. With a low i.f. the second channel is close to the main channel and the sharp null in between provides accurate frequency location. This instrument costs £250 and is manufactured by Airmec Ltd., of High Wycombe, Bucks.

### Transistorized Counter

THE new Advance TC1 can measure any time from 1 $\mu$ sec to 10<sup>7</sup> sec or any frequency from 10c/s to 10<sup>6</sup>c/s over periods of 1 or 10 cycles or 0.1, 1 or 10sec. Regular or random pulses can be counted over any period determined by the user. The display time can be varied between 1 and 5 sec; alternatively the display can be held permanently. Pulses at frequencies variable in decade steps from 10<sup>-1</sup>/sec to 10<sup>6</sup>/sec are also provided. The operation of the counters can be checked by counting the internal standard oscillations over a period of 10sec. These standard oscillations are provided by a 1Mc/s crystal oscillator. When the TC1 is operated from the mains this oscillator is oven controlled to provide an accuracy of  $\pm 5$  parts in 10<sup>6</sup> over the temperature range from 0°C to 40°C. The TC1 can alternatively be operated from a 6-V battery, but the oven is then switched off and the error can thus increase to  $\pm 15$  parts in 10<sup>6</sup> over the same temperature range (from 0°C to 40°C). This counter costs £425 and is manufactured by Advance Components Ltd., of Roebuck Road, Hainault, Ilford, Essex.

### Low-Capacity Bridge

IN the Marconi TF1342 capacitors are measured by means of a transformer ratio-arm bridge. This eliminates errors due to any impedances between either of the two capacitor terminals and a third point so that long leads can be used to connect the bridge to the capacitor being measured and *in situ* measurements can be made. Effective capacitor shunt resistances in the range 1M $\Omega$  to 1000M $\Omega$  can be balanced out. Capacitances ranging from 1111pF down to 0.002pF can be measured to an accuracy of 0.2%. An internal 1000c/s oscillator and detector are included. So as to facilitate balancing, a progressive increase in detector sensitivity as the balance point is approached is provided by means of a.g.c. The TF1342 costs £135 and is manufactured by Marconi Instruments Ltd., of St. Albans, Herts.

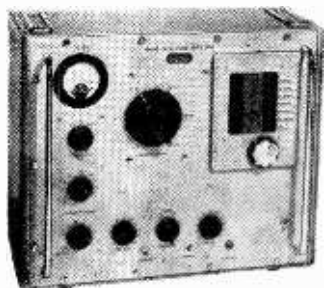

Airmec Type 248 v.h.f. wave analyser

Advance Type TC1 transistorized counter



Marconi Type TF1342 low-capacitance bridge

## CONFERENCES AND EXHIBITIONS

Latest information on forthcoming events both in the U.K. and abroad is given below. Further details are obtainable from the addresses in parentheses.

LONDON		
May 3-13	<b>Mechanical Handling Exhibition</b> ( <i>Mechanical Handling</i> , Dorset House, Stamford Street, London, S.E.1.)	Earls Court
May 23-28	<b>Instruments, Electronics and Automation Exhibition</b> (Industrial Exhibitions Ltd., 9 Argyll St., London, W.1.)	Olympia
July 21-27	<b>Medical Electronics Conference and Exhibition</b> (I.E.E., Savoy Place, London, W.C.2.)	Olympia
Aug. 24- Sept. 3	<b>National Radio and Television Show</b> (Radio Industry Exhibitions Ltd., 59 Russell Square, London, W.C.1.)	Earls Court
Sept. 1	<b>Rocket and Satellite Instrumentation</b> (Society of Instrument Technology, 20 Queen Anne Street, London, W.1.)	26 Portland Pl.
Nov. 21-25	<b>Industrial Photographic and TV Exhibition</b> (Industrial and Trade Fairs Ltd., Drury House, Russell Street, London, W.C.2.)	Albert Hall
Nov. 23-26	<b>Radio Hobbies Exhibition</b> (P. A. Thorogood, 35 Gibbs Green, Edgware, Middx.)	R.H.S. Old Hall
CAMBRIDGE		
Sept. 15-17	<b>R.S.G.B. National Convention</b> (Radio Society of Great Britain, Little Russell Street, London, W.C.1.)	
FARNBOROUGH		
Sept. 5-11	<b>Farnborough Air Show</b> (Society of British Aircraft Constructors, 29 King Street, London, S.W.1.)	
MANCHESTER		
Sept. 21- Oct. 1	<b>International Factory Equipment Exhibition</b> (Industrial and Trade Fairs Ltd., Drury House, Russell Street, London, W.C.2.)	Belle Vue
OVERSEAS		
May 1-7	<b>S.M.P.T.E. Convention and Exhibition</b> (Society of Motion Picture and Television Engineers, 55 W. 42 Street, New York, 36.)	Los Angeles
May 2-4	<b>Aeronautical Electronics Conference</b> (I.R.E., Dayton, Ohio.)	Dayton
May 10-12	<b>Instrument-Automation Conference</b> (Instrument Society of America, 313 Sixth Avenue, Pittsburgh, 22, Pa.)	San Francisco
May 24-26	<b>A.F.C.E.A. Convention and Show</b> (Armed Forces Communications and Electronics Association, 1624 Eye Street, N.W., Washington.)	Washington
June 7-11	<b>International Congress on Microwave Tubes</b> (Prof. Dr. W. Kleen, Balanstrasse 73, Munich, 8.)	Munich
June 10-26	<b>British Exhibition</b> (British Overseas Fairs, 21 Tothill St., London, S.W.1.)	New York
June 13-17	<b>Technical Writers' Institute Convention</b> (Technical Writers' Institute, Troy, N.Y.)	Troy
June 15-29	<b>Nuclear and Electronic Congress and Exhibition</b> (Fairs and Exhibitions, 2 Dunraven St., London, W.1.)	Rome
June 18-29	<b>British Scientific Instrument Exhibition</b> (S.I.M.A., 20 Queen Anne Street, London, W.1.)	Moscow
June 27-29	<b>National Convention on Military Electronics</b> (I.R.E., 1 East 79 Street, New York.)	Washington
June 27- July 7	<b>Automatic Control Congress</b> (B.C.A.C., c/o I.E.E., Savoy Place, London, W.C.2.)	Moscow
Aug. 23-26	<b>Western Electronic Show and Convention</b> (Wescon, 1435 South La Cienega Boulevard, Los Angeles.)	Los Angeles
Aug. 29- Sept. 2	<b>Physics of Semiconductors Conference</b> (International Union of Pure and Applied Physics, 3 Boulevard Pasteur, Paris, 15.)	Prague
Aug. 30- Sept. 6	<b>Firato—International Radio Show</b> (Firato Secretariat, Emmalaan 20, Amsterdam, Z.)	Amsterdam
Sept. 19-22	<b>Space Electronics and Telemetry</b> (I.R.E., 1 East 79 Street, New York.)	Washington
Sept. 21-22	<b>Industrial Electronics Symposium</b> (I.R.E., 1 East 79 Street, New York.)	Cleveland
Sept. 26-30	<b>Instrument-Automation Conference</b> (Instrument Society of America, 313 Sixth Ave., Pittsburgh 22, Pa.)	New York
Oct. 3-5	<b>Communications Symposium</b> (I.R.E., 1 East 79 Street, New York.)	Utica
Oct. 10-12	<b>National Electronics Conference</b> (I.R.E., 1 East 79 Street, New York.)	Chicago
Oct. 19-26	<b>Interkama—Congress and Exhibition for Instrumentation and Automation</b> (Nordwestdeutsche Ausstellungen, Ehrenhof 4, Dusseldorf.)	Dusseldorf
Nov. 14-16	<b>Mid-American Electronics Convention</b> (MAECON, Bendix Aviation Corp., P.O. Box 1159, Kansas City, 41, Mo.)	Kansas City
Nov. 15-17	<b>Electronics Research and Engineering Meeting</b> (I.R.E., 73 Tremont Street, Boston, Mass.)	Boston

## Mikes and Mixers



### RIBBON MICROPHONE Model G7823

Now smaller, this new design gives improved performance, minimising feedback effects while improving frequency response and sensitivity.

Model G7823 is complete with screened connector plug and locking ring, and beautifully finished in satin chrome. A silent switch adaptor G7819 is also available.

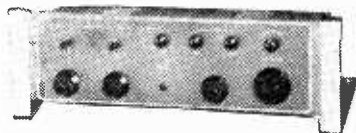

### New Mixer Preamplifier Model EM3/Mk. III

Inputs for 2 mics. and one pick-up or tuner, master control and selector, 4 valves, independent tone controls. Built on 19in. panel for desk or rack mounting.

Model EM6/Mk. III Similar unit with 6 inputs.

# TRIX

THE TRIX ELECTRICAL CO. LTD.,  
1-5 MAPLE PLACE, LONDON, W.1.

Tel. Museum 5817 (6 lines)  
Grams: Trixradio Wesdo London

# RANDOM RADIATIONS

By "DIALLIST"

## Thirteen-channel Sets?

WHEN Mendlesham came into service on Channel 11 some people in its service area found that what they'd bought as 13-channel receivers were in fact nothing of the kind. Many sets with turret tuners described in this way are (or at any rate were) sent out by manufacturers with the coils for only some of the stations and those who bought them were naturally pretty annoyed by having to pay extra for the new "bis-cuits." If a set is sold as a 13-channel receiver, it should undoubtedly be able to receive stations using any of them without additions or alterations being necessary. Certainly the purchaser should not have to pay extra if he wants to get a particular station and finds that it isn't provided for. It's not only those who live and have their being in the service area of a particular station who are affected. Some stations serve a good many popular holiday resorts and in these days of portable television sets people like to be able to put the set into the car with the rest of the luggage and to use it when they get to their destination. I fancy that a good few holiday-makers will be (to say the least of it) annoyed when they find that there's no response when the selector switch is tuned to the channel of the local station. *Verb. Sap.:* when you buy a 13-channel set make sure that it is what it claims to be.

## A Nine-colour Code?

MY recent note on colour coding for the wiring of mains plugs has prompted J. C. Rudge, of Hanworth, Middx., to suggest that a ninefold colour-code should be used in the wiring of all electronic apparatus. Although I can't support so far-reaching a suggestion, nor do I think it necessary, here it is:—

Yellow.	Signal.
Red.	Steady positive potential.
Orange.	Signal at a positive potential.
Blue.	Steady negative potential.
Green.	Signal at a negative potential.
Black.	Earth.
Brown.	Signal at earth potential.
White.	Pure A.C. (any frequency).
Mauve.	Anything needing distinguishing from the above.

My own feeling is that with a nine-colour code there'd be frequent mistakes made in the wiring. And even if that didn't happen, trouble-hunters

would require good memories to keep all nine in mind and not get them mixed up. But surely a stronger reason against the adoption of so elaborate a code is that the printed panel is steadily superseding conventional wiring. No one can have much doubt that in the not so distant future few, if any, internal connections will be made by wires. It's foolish nowadays to say that anything is impossible; but I can't see how connections calling for nine different colours could be printed quickly and economically. That's how I feel, anyhow. You perhaps may have quite different views on the subject.

## A Transistor Point

SO far as I know, there's no mains-operated transistor receiver (on the lines of that described by T. Snowball last September) on the market. You may ask why there should be, for the transistor's needs in the way of e.m.f. and current are so small that they can easily be supplied by a small dry battery. That's true enough; but good and convenient as it is, the dry battery has two drawbacks. One is that when it's under load the e.m.f. of such a battery is constantly falling. The other, which is much more serious, is that if the battery is inadvertently left in the set in a nearly run-down state, one or more of the cells

may puncture, allowing a horrid mess to ooze out, whose effects on delicate apparatus can be devastating. Many of us have had the experience of finding a flashlamp or a child's toy ruined when it has been left for some time with the battery inside it. I had a narrow escape once with the resistance-measuring department of a multi-range meter. And the same thing might happen to a transistor receiver if one were taken ill, or forgot to remove the battery before going away for some time.

## A Radar Simulator

HAVING had something to do in a consultant capacity with legal actions over collisions between ships, I've been surprised more than once by the failure of navigating officers to make full and proper use of radar in conditions of poor visibility. They hadn't bothered to plot the courses of their own ship and others shown on the screen. By very simple plotting you can quickly find the speed of any ship which seems at all dangerous and work out whether or not you and she are on collision courses. Plotting is simplified when using true-motion type radar or a "nearest-approach" calculator such as that described by A. L. P. Milwright in *Wireless World* in October 1957. I'm glad to see that radar simulator courses for senior deck officers are



## "WIRELESS WORLD" PUBLICATIONS

	Net Price	By Post
<b>ELECTRONIC COMPUTERS' Principles and Applications.</b> T. E. Ivall, 2nd Edition .. .. .	25/-	26/-
<b>TELEVISION RECEIVING EQUIPMENT.</b> W. T. Cocking, M.I.E.E. 4th Edition .. .. .	30/-	31/9
<b>TRANSISTOR A.F. AMPLIFIERS.</b> D. D. Jones, M.Sc., D.I.C., and R. A. Hilbourne, B.Sc.	21/-	21/10
<b>LONG-WAVE AND MEDIUM-WAVE PROPAGATION.</b> H. E. Farrow, Grad.I.E.E. .. .. .	4/6	4/10
<b>RADIO CIRCUITS: A Step-by-Step Survey.</b> W. E. Miller, M. A. (Cantab.), M.Brit.I.R.E. Revised by E. A. W. Spreadbury, M. Brit.I.R.E.	15/-	15/10
<b>GUIDE TO BROADCASTING STATIONS, 12th Edition ..</b>	3/6	4/-
<b>PRINCIPLES OF TRANSISTOR CIRCUITS.</b> S. W. Amos, B.Sc. (Nons.), A.M.I.E.E. .. .. .	21/-	21/11
<b>MICROWAVE DATA TABLES.</b> A. E. Booth, M.I.R.E., Graduate I.E.E. .. .. .	27/6	28/8
<b>PRINCIPLES OF FREQUENCY MODULATION.</b> B. S. Camies .. .. .	21/-	21/10

A complete list of books is available on application.  
Obtainable from all leading booksellers or from

ILIFFE & SONS LTD., Dorset House, Stamford Street, London, S.E.1

being run at the Sir John Cass College in London. The simulator was designed and made by Redifon and the displays are on Marconi "Radio-locator IV" screens. The equipment belongs to Shell Tankers, Ltd., and is on loan to the College. The instructor can put all kinds of tricky situations on to the display units and the officer under instruction can produce the effects of altering the course and speed of his own imaginary ship to meet the emergencies.

### Viewing Glasses

A READER who is a practising optician doesn't agree with my remarks in the March issue of *Wireless World* about the prescription of special viewing spectacles focusing at five or six feet. He bears me out that if the acuity of vision is normal, lenses focusing at about 10 feet should give comfortable viewing with a 17-in TV screen. "However," he writes, "there are cases (mainly elderly people) in which a normal standard of vision cannot be obtained even with the best of lenses. In such cases it is sometimes useful to prescribe a special correction to be used at 5 to 6 feet. In these cases I find that a smaller screen is often preferred." His last sentence is, I feel, important, for it seems to support my contention that at 5-6 feet an image on a 17-inch tube is pretty well bound to be liney. Six feet, however, would be a comfortable viewing distance from a 12-in screen with eyes not so sharp as they used to be.

### Noise

DID you happen to listen to the B.B.C.'s programme on "noise" in Matters of Moment some weeks ago? I found it very interesting, for I've been a lifelong hater of what the B.S.I. calls "sound undesired by the recipient." Ours is, you know, a very noisy age and so far we've done very little to improve things. People who rode motor bicycles with half the innards of the silencer removed or, worse still, with the silencer put right out of action by means of a cut-out used to be run in and fined. How often does that happen now? Wireless sets, too, can be the cause of a great deal of highly offensive noise, particularly in summer time if they're used in rooms with wide open windows, or out of doors. The set that's worked all out is pretty sure to be distorting badly and any distortion that's there is emphasized by distance.

# THE BULGIN BULLETIN

Electronic Engineers the world over, take the opportunity of receiving month by month our fully illustrated Electronic Component Bulletin. Produced with Industry in mind, it deals with the latest developments and additions to the extensive range of Electronic Components manufactured by the House of Bulgin. If you wish your name to be included on our mailing list for future issues of this publication, write to-day attaching **trade or professional letterhead** to the address shown below.

## CATALOGUE

The House of Bulgin is pleased to announce the publication of a new 1960 Catalogue containing full working details and dimensions of

**OVER 10,000 ELECTRONIC COMPONENTS**

Available free on request to all Manufacturers and Electronic Engineers who have not already applied. **QUOTE REF.: 201/C.**

★ **WRITE** ↓ **NOW** ★

**A. F. BULGIN & CO., LTD. · BYE-PASS RD. BARKING, ESSEX.**  
**TELEPHONE: RIP 5588 (12 lines)**

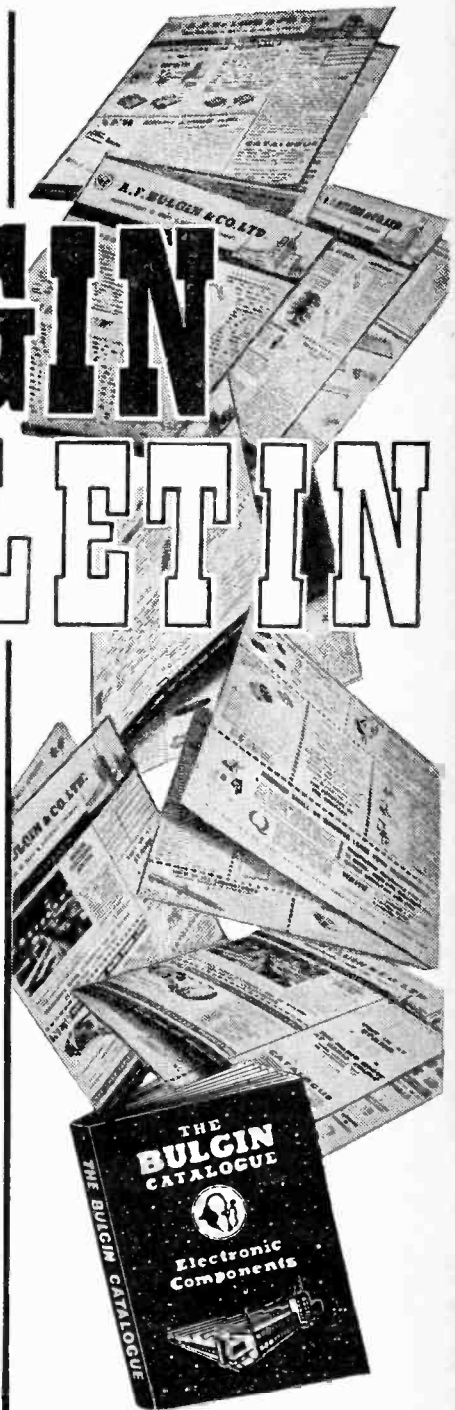

## Jodrell Bank

NOWADAYS we hear a lot about the radio telescope at Jodrell Bank, and for a long time past I have thought that the name radio telescope is an utterly inadequate one. To the ordinary public the name suggests that it is merely an outsize in telescopes which, by some special radio means, peers a bit farther into space than the ordinary sort of telescope at the seaside into which we push a penny to view the wonders of the heavens or the beauties of the shore and sea. In any case, even the ordinary optical telescope is entitled to the prefix "radio" for surely it handles the very short electromagnetic or radio waves in the optical spectrum.

Only last summer I sat in a deck chair hard by one of these devices at Southend where, of course, a telescope is always necessary at low tide to view the distant bathing belles over the acres of intervening mud. A young man who had been having a pennyworth of dekkko at the distant damsels, shook his head sadly, as he complained of the mere 20x magnification of the telescope, and re-



To view the beauties of the shore and sea.

marked to me what a wonderful time the Jodrell Bank scientists must have with their super telescope.

It was obvious to me that he was completely misled by the use of the very inadequate term radio telescope and I cannot say I was surprised. I am aware that the word "scope" means "examine" and does not necessarily imply "examine by optical means"; we have a very striking example of its non-optical use in the doctor's stethoscope.

In the case of the Jodrell Bank instrument, I suppose that at a pinch we could say that to an intelligent member of the public, the prefix "radio" describes its *modus operandi* but the word telescope can hardly be said to deal adequately with its *quod faciendi*.

What we want is an entirely new word. Can any of you help in this respect?

## All About Electricity

A MOST interesting publication fell into my hands the other day entitled "All About Electricity." Electricity is one of the things I have always wanted to know all about, and so I naturally devoured the pages of the book eagerly. But electricity is as fathomless as a woman; the more you know, the more you know there is more to know than you will ever know.

I must admit that the book was written for women and it would, therefore, be difficult for any mere male to understand it. It is published by the Eastern Electricity Board under the auspices of the National Union of Townswomen's Guilds, and I daresay Electricity Boards in other areas publish it also.

For the benefit of those men whose womenfolk do not belong to the local Townswomen's Guild and who, therefore, know nothing about the Guild's activities, I would describe it as a sort of club where married women meet to discuss their respective husbands' failings. Single women are not barred and are, no doubt, instructed by their married sisters how to manage a husband. They also obviously learn other things such as all about electricity.

Now as the book is admittedly written for women, I have only minor criticisms to make. I suppose a good subtitle for it would be "Technicalities without Tears," as it does endeavour to explain to women such things as the purpose of a fuse, although I think it ought to warn them that a hairpin or safety pin should not be pressed into service as a makeshift fuse even in an emergency.

One thing about the book does puzzle me greatly, and that is this. The book deals with volts, amps and watts and then suddenly, after mentioning ampères, the author interpolates the seemingly irrelevant piece of information that Ampère was the name of a famous French scientist. Perfectly true, of course, but why

does the writer ignore our own home-grown James Watt or the Italian Volta?

To me the reason seems to be solely that Ampère was French, and to a clothes-conscious woman anything that does not come from Paris—or at least France—is not worth worrying about. This subtle touch shows that the writer of the book is probably a woman. Also, of course, the fact that one of Ampère's Christian names was Marie may have influenced her with giving him special mention.

There is one further point. The book tells me that I must not use my electric dry shaver in the bathroom except from a specially designed socket with an isolating transformer in it.

I telephoned three showrooms of my local Electricity Board to know where I could get such a device but they could not help me. I fared no better at the stand of the Electrical Development Association at the Ideal Home Exhibition at Olympia. It then occurred to me to 'phone *incognito* the information service of our associate journal, the *Electrical Review*, and I received the information at once without any turning up of reference books.

## Marconiana

AT times one finds astonishing and hitherto unpublished pieces of information in reference books. One of the most astonishing to me is something I read recently about Marconi's early experiments. The edition of the book in which I read it appeared as recently as 1957, its author being a D.Sc. and an M.A., and the firm sponsoring the book describe themselves as educational publishers.

The author, discussing the work of Marconi, says, "There were several scientists experimenting with *sound waves* [italics mine] and trying to transmit them without wires. Marconi joined them. He was the first to find a method of doing so. At first he managed to send a message across a field. . . ."

My only comment is that this is the first time I knew that prior to his radio experiments Marconi used a megaphone or possibly tried out the old method of transmitting sound waves by boring a hole in the bottoms of two cocoa tins and threading through each hole a length of string with a knot on each end. When I was a boy, this certainly worked very well provided, of course, we kept the string reasonably taut, but the breadth of a garden was my limit.